



The information in this manual is the property of Harsco Industrial Patterson-Kelley. The descriptions and specifications contained in this manual were in effect at the time this manual was approved for publication. While Harsco Industrial Patterson-Kelley will continue to support earlier model boilers to within a reasonable time limit, we reserve the right to discontinue models and replacement parts at any time or change specifications or design without notice and without incurring any obligation.

# Safety

## General

### P-K HiDRA™ Water Heaters (HC800, HC1000)

All P-K HiDRA™ Gas-Fired Water Heaters:

- Installed, operated, and serviced in accordance with instructions contained in this manual and other supplemental manuals.
- Installed by qualified personnel in accordance with designs prepared by qualified facility engineers including: structural, mechanical, electrical, and other applicable disciplines.
- Operated and serviced in accordance with a comprehensive safety program determined and established by the customer. Do not attempt to operate or service until such a program has been established.
- Operated and serviced by experienced, qualified, and properly trained personnel in accordance with all applicable codes, laws, and regulations.

## Safety Precautions

Provide a suitable location for the appliance, away from normal personnel traffic, with adequate working space, adequate clearances, proper ventilation and lighting, with a structure sufficiently strong and rigid to support the weight of the appliance, all piping, and accessories.

### **WARNING**

Crystalline silica may be present in this equipment. Exposure to crystalline silica may pose significant health hazards, including but not limited to eye and respiratory system damage. Personal Protective Equipment must be worn to minimize exposure to hazardous substances. Refer to most current guidelines by the CDC and OSHA for more information, including Personal Protective Equipment recommendations.

### **NOTICE!**

Each safety device must be maintained and checked per the recommended schedule. Refer to [5 Maintenance](#).

### **SAFETY FEATURES**

It is the responsibility of the customer to ensure external safety provisions, such as, but not limited to: guards, safety labels, safety controls, interlocks, lockout devices are in place and operable.

### **SAFETY LABELS**

The following words are used in this manual to denote the degree of seriousness of the individual hazards.

### **DANGER**

*Indicates an imminently hazardous situation which, if not avoided, will result in death or serious injury. This signal word is to be limited to the most extreme situations.*

### **WARNING**

**Indicates a potentially hazardous situation which, if not avoided, could result in death or serious injury.**





### **CAUTION**

Indicates a potentially hazardous situation which, if not avoided, may result in minor or moderate injury. It may also be used to alert against unsafe practices.

### **NOTICE/NOTE - NOTICE**

	 <b>WARNING</b>
	<p><b>Improper use may result in fire or injury.</b></p> <p>Read instructions/safety manual before installing, operating or servicing appliance.</p>

Is the preferred signal word to address practices not related to personal injury. The safety alert symbol is not used with this signal word.

<p> <b>AVERTISSEMENT</b></p> <p>Une installation, un réglage, un changement ou un entretien inappropriés peuvent causer des dommages matériels, des blessures corporelles ou la mort.</p> <p>Lire et bien comprendre le Manuel d'installation et du propriétaire fourni avec cette appareil. L'installation et le service doivent être effectués par un personnel expérimenté et compétent qui a reçu une formation sur l'appareil de cette série.</p>	  	<p> <b>WARNING</b></p> <p>Improper installation, adjustment, alteration, service, or maintenance can cause property damage, personal injury or loss of life.</p> <p>Read and understand the installation and Owner's manual provided with this appliance. Installation and service must be performed by experienced and knowledgeable personnel who have been trained on this series appliance.</p>
---	--	--

PRELIMINARY DOCUMENT - SUBJECT

## NOTICE!

The safety labels shown below are affixed to your appliance. Although the labels are of high quality, they may become dislodged or unreadable over time. Contact Harsco Industrial Patterson-Kelley at **570.476.7261** or toll-free at **877.728.5351** for replacements.

<p><b>AVERTISSEMENT</b></p> <p>Une installation, un réglage, un changement ou un entretien inappropriés peuvent causer des dommages matériels, des blessures corporelles ou la mort.</p> <p>Lire et bien comprendre le Manuel d'Installation et de programmation fourni avec cette appareil. L'installation et le service doivent être effectués par un personnel expérimenté et compétent qui a reçu une formation sur l'appareil de cette série.</p>		<p><b>WARNING</b></p> <p>Improper installation, adjustment, alteration, service, or maintenance can cause property damage, personal injury or loss of life.</p> <p>Read and understand the installation and Owner's manual provided with this appliance. Installation and service must be performed by experienced and knowledgeable personnel who have been trained on this series appliance.</p>
--	---	--

<p><b>ATTENTION</b></p> <p>Risque de brûlures. Certains composants sont très chauds. Allouer un temps de refroidissement après l'arrêt et ne pas toucher pendant le fonctionnement.</p>		<p><b>CAUTION</b></p> <p>Burn hazard. Some components are hot to the touch. Allow time to cool after shutdown and do not touch during operation.</p>
---	---	--

<p><b>AVERTISSEMENT</b></p> <p>Risque électrique. Un contact causera un choc électrique et des blessures. Suivre les procédures de verrouillage/étiquetage lors de l'entretien.</p>		<p><b>WARNING</b></p> <p>Electrical Hazard. Contact may cause electrical shock and injury. Follow lockout/tagout procedure when servicing.</p>
---	---	--

	<p><b>WARNING</b></p> <p>Improper use may result in fire or injury. Read instructions/safety manual before installing, operating or servicing appliance.</p>
---	--

### **WARNING**

Gas may lose its odor. Proper gas sensing equipment and procedures should be used for leak checks. Failure to detect gas leaks could result in injury or death.

## Training

Proper training is the best protection against accidents. It is **essential** to read, understand, and follow the recommendations of this manual before installing, operating, or servicing this equipment. Failure to do so could result in fire or explosion and serious injury, death, and/or property damage.

Operating and service personnel must be thoroughly familiar with the basic construction of the 800 and 1000 appliances, the use and locations of the controls, the operation of the appliance, adjustment of their various mechanisms, and all applicable safety precautions. If any of the provisions of this manual are not fully and completely understood, contact Harsco Industrial Patterson-Kelley Technical Service at **570.476.7261** or toll free at **877.728.5351**.

## Hazard Warnings

### Electrical Hazards



**Shock Hazard!** Properly lockout/tagout the electrical service and all other energy sources before working on or near the appliance.

**Shock Hazard!** Do not spray water directly on this appliance or any electrical components.

**Electrical Hazard!** Do not alter wiring connections.

### Crush Hazards



**Lifting Hazards!** Use properly rated lifting equipment to lift and position the appliance. The load is unbalanced. Test the balance before lifting off the floor. Do not allow personnel beneath the lifted load. Refer to the approximate weights in the table.

Water Heater Model	Weight in Pounds
HC800	1000
HC1000	1000

### Bump Hazard from Overhead Ductwork and Piping



**Injury Hazard!** Install components with adequate vertical clearance.

### Pressure Hazards



**Pressure Hazard!** Hot fluids. Install isolation valves on appliance water inlet and outlet. Make sure isolation valves are closed before servicing appliance.

**Pressure Hazard!** Hot fluids. Annually test safety relief valve(s) for proper operation. Do not operate appliance with faulty relief valve(s).

## Slip, Fall Hazards



**Tripping Hazard!** Do not install piping on floor surfaces. Maintain a clear path around the appliance.

**Slip and Fall Hazard!** Use a drip pan to catch water while draining the appliance. Maintain dry floor surfaces.

**Slip and Fall Hazard!** Do not locate intake or exhaust terminations above a walkway; dripping of condensate can cause icing of the walking surface. Refer to [3.4.5 Required Clearances](#).

**Fall Hazard!** Do not stand on appliance.

## Chemical Hazards

**Chemical Hazards from Cleaning Products.** Use caution when cleaning the system. The use of professional assistance is recommended. Use safe procedures for the disposal of all cleaning solutions.



**Combustion Condensate** – An acidic pH of approximately 3.0 to 5.0 can be expected. Use PVC, CPVC, or other corrosion resistant piping for drainage. Collection and disposal must be in accordance with all applicable regulations. A condensate neutralization kit is available. Please contact your local Harsco Industrial Patterson-Kelley representative for more information.



## Burn, Fire and Explosion Hazards



**Burn, fire, and explosion hazards!** Installation must be in strict conformance to all applicable codes and standards including NFPA 54, ANSI Z223.1 and CAN/CSA B.149. Install all required vent lines for gas devices. Refer to Section [3.6](#).

**Hazard from Incorrect Fuels!** Possible fire, explosion, overheating, and damage. Do not use any fuels except the design fuels for the unit.

**Overfire Hazards!** High pressure in gas supply could result in overfiring of this or other devices supplied from the same source.

**Fire and Explosion Hazards!** Close the main gas shutoff before servicing appliance.

**Fire and Explosion Hazards!** Do not store or use gasoline or other flammable vapors or liquids in the vicinity of this or any other gas fired appliance.



**Burn hazard!** Possible hot surfaces. Do not touch gas vent during firing operation. Use only factory recommended vent components.

**Burn Hazard!** Pipes, vents, and appliance components could be hot. Do not touch piping or stack surfaces during operation or immediately after shutdown of the appliance.

**Burn Hazard!** Hot flue! Use caution when servicing or draining appliance.

**Fire and Explosion Hazards!** Use caution when servicing burner. Propane (LPG) is heavier than air and may linger in the combustion chamber, vent lines, or elsewhere.

**Gas Leak Hazard!** Make sure the burner is installed correctly and blower/transition is securely fastened following any maintenance performed on them. These connections may leak gas if assembled incorrectly.

**Gas Leak Hazard!** All threaded gas connections must be made using a pipe compound that is resistant to liquefied petroleum gas. Do not use Teflon™ tape on threaded gas piping.

**Gas Leak Hazard!** Check entire gas train for leaks after installation. If there is a smell of gas, shut down the appliance and obtain immediate assistance from trained service personnel and/or your local fire department.

**Overfire Hazard!** Possible fire and explosion from excess gas pressure. Make sure that gas inlet pressure does not exceed 14 inches W.C.

**Overfire Hazard!** Possible fire and explosion. Possible malfunction of regulators and/or gas safety shut off/control valves. Maintain all gas train components in good condition. Do not alter wiring connections. Annual inspection by factory-trained personnel for proper set-up and operation is recommended.

**Overfire and Underfire Hazards!** Possible fire, explosion, overheating, and component failure. Do not attempt to adjust firing rate of the appliance. The firing rate must be adjusted only by factory trained personnel.

**⚠ DANGER**

- Water temperature over 125°F can cause severe burns instantly or death from scalds.
- Children, disabled and elderly are at highest risk of being scalded.
- See instruction manual before setting temperature at water heater.
- Feel water before bathing or showering.
- If this appliance is used to produce water that could scald if too hot, such as domestic hot water use, adjust the outlet control (limit) or use temperature limiting valves to obtain a maximum water temperature of 120°F.
- Une température de l'eau plus grande que 125°F peut causer brulures sévères immédiatement ou mort par échaudage.
- Les enfants, les personnes handicapées et les personnes âgées sont le plus haut risque d'échaudage.
- Regardez le manuel avant régler la température a le chauffe-eau.
- Sentir l'eau avant se baigner.
- Si cette appareil utilisé produit l'eau que pourrait bruler, comme l'eau chaude domestique, régler le contrôle de sortie ou utiliser vannes que limiter la température obtenir maximale à 120°F.

PRELIMINARY DOCUMENT - SU



# Table of Contents

<b>1</b>	<b>INTRODUCTION .....</b>	<b>3</b>
1.1	PURPOSE OF THIS DOCUMENT .....	6
1.2	COMMON ABBREVIATIONS .....	6
<b>2</b>	<b>SITE PREPARATION .....</b>	<b>7</b>
2.1	INITIAL INSPECTION UPON RECEIVING .....	7
2.2	STORAGE PRIOR TO INSTALLATION.....	7
2.3	COMPLIANCE WITH CODES.....	8
2.4	LOCATION SETUP .....	9
2.4.1	Foundation .....	9
2.4.2	Clearances .....	9
2.5	GAS PIPING CONSIDERATIONS .....	11
<b>3</b>	<b>INSTALLATION.....</b>	<b>11</b>
3.1	OVERVIEW.....	11
3.2	APPLIANCE CONNECTIONS.....	11
3.2.1	Water Heater System Guidelines.....	12
3.2.2	Appliance Piping (for Installer) .....	12
3.3	ELECTRICAL CONNECTIONS .....	14
3.3.1	Power Requirements .....	14
3.3.2	High Voltage (TB2) Terminal Block .....	15
3.3.3	Low Voltage (TB1) Terminal Block .....	16
3.3.4	Terminal Block Assignments — Low Voltage (TB1) Terminal Block .....	16
3.3.5	Terminal Block Assignments — High Voltage (TB2) Terminal Block.....	18
3.3.6	Wiring Diagram.....	19
3.4	INLET AIR AND EXHAUST VENTING CONSIDERATIONS .....	21
3.4.1	Applicable Codes and Standards.....	21
3.4.2	Combustion Air Inlet Planning (United States and Canada Considerations) .....	21
3.4.3	Category II/IV Flue Gas Exhaust Vent Planning .....	22
3.4.4	Venting Materials for Flue/Exhaust Systems .....	23
3.4.5	Required Clearances .....	24
3.5	COMBUSTION AIR .....	27
3.5.1	Air Inlet Requirements – United States .....	27
3.5.2	Air Inlet Requirements – Canada .....	28
3.5.3	P-K HiDRA™ Combustion Air Requirements .....	29
3.5.4	Flue Venting Installation .....	29
3.6	FLUE GAS / EXHAUST VENTING .....	29
3.6.1	Category II Installations .....	30
3.6.2	Category IV Installations.....	33
3.6.3	Sealed Combustion/Direct Vent Systems.....	33
3.6.4	Flue Connection .....	37
3.6.5	Venting for Multiple Appliances .....	37
3.6.6	Stainless Steel Venting.....	37
3.6.7	CPVC Vent System Installation .....	39
3.6.8	CONDENSATE DRAIN, TRAP & DISPOSAL .....	40
3.7	PIPING.....	41
3.7.1	Gas Piping Overview .....	41
3.7.2	Natural Gas Piping .....	42
3.7.3	Pressure Testing the Gas Piping .....	42
3.7.4	Gas Supply Piping for Installer .....	43

3.7.5	Appliance Connections	43
3.8	WATER QUALITY	44
3.9	PRE-START CHECKLIST	45
3.10	SAFETY CHECKS	46
3.10.1	Ignition Safety System Test	46
3.10.2	Manual Reset High Temperature Limit Test	46
3.10.3	Gas Pressure Switch Tests	46
3.10.4	Low Water Cut-out Test	47
<b>4</b>	<b>OPERATIONS</b>	<b>48</b>
4.1	NURO® CONTROL PANEL	48
4.1.1	NURO Touch Screen Interface	48
4.1.2	Factory Tests	48
4.2	NORMAL LIGHTING AND SHUT-DOWN PROCEDURES	49
4.2.1	Normal Lighting Procedures	49
4.2.2	Normal Shut Down Procedures	49
4.3	EMERGENCY SHUT-OFF	49
4.4	FUEL/AIR ADJUSTMENTS	49
4.4.1	Inlet Gas Port	49
4.4.2	Combustion Setup and Adjustment	51
4.4.3	Adjusting High Fire (DUNGS Valve)	52
4.4.4	Adjusting Low Fire (DUNGS Valve)	52
4.4.5	Adjusting High Fire (Honeywell Valve)	53
4.4.6	Adjusting Low Fire (Honeywell Valve)	53
4.5	INITIAL NURO CONTROL SETUP & ADJUSTMENT	55
4.5.1	Startup	55
4.5.2	Home Screen	56
4.5.3	Information Screen	56
4.6	TYPICAL OPERATING CONDITIONS	57
<b>5</b>	<b>MAINTENANCE</b>	<b>58</b>
5.1	PREVENTATIVE MAINTENANCE	58
5.1.1	Daily Preventative Maintenance	58
5.1.2	Weekly Preventative Maintenance	58
5.1.3	Monthly Preventative Maintenance	59
5.1.4	Semi-Annually	59
5.1.5	Annually	59
5.2	CLEANING THE BURNER & COMBUSTION CHAMBER	60
5.3	AFTER REPAIRS OR MAINTENANCE	62
5.4	SEQUENCE OF OPERATIONS	63
5.5	TROUBLESHOOTING	63
5.5.1	Loss of Power	64
5.5.2	Loss of Water Flow	64
5.5.3	Low Gas Pressure	64
5.5.4	High Gas Pressure	64
5.5.5	High Water Temperature	64
5.5.6	Low Air	64
5.5.7	Low Air Intake Pressure	65
5.5.8	Flame Failure	65
5.5.9	Flame Error	65
5.5.10	Flue Problem	65



<b>6</b>	<b>PARTS/TECHNICAL SUPPORT .....</b>	<b>66</b>
6.1	APPLIANCE PARTS IDENTIFICATION .....	67
6.1.1	Main Appliance Assembly.....	67
6.1.2	NURO® Control Panel.....	68
6.1.3	Heat Exchanger Assembly .....	69
6.1.4	Natural Gas Train (DUNGS Valve) .....	70
6.1.5	Natural Gas Train (Honeywell Valve).....	71
6.1.6	Blower Assembly.....	72
6.1.7	Burner Assembly .....	73
<b>7</b>	<b>P-K HIDRA™ SPECIFIC LIMITED WARRANTY .....</b>	<b>73</b>
<b>8</b>	<b>APPLIANCE FIRE-TEST REPORT .....</b>	<b>76</b>
	<b>APPENDIX A – MAINTENANCE LOG .....</b>	<b>77</b>
	<b>APPENDIX B – APPLIANCE ALTITUDE DERATE SCHEDULE .....</b>	<b>78</b>
	<b>APPENDIX C – WATER QUALITY STANDARDS .....</b>	<b>79</b>
	<b>APPENDIX D BEST PRACTICES FOR NEW &amp; RETROFIT SYSTEMS .....</b>	<b>80</b>
	<b>APPENDIX E – INSTALLATION AND QUICK REFERENCE .....</b>	<b>81</b>
	FUEL/GAS SUPPLY .....	81
	ELECTRICAL/POWER SUPPLY .....	81
	EXHAUST VENTING .....	81
	APPLIANCE CONNECTIONS .....	82

## 1 Introduction

### **WARNING**

If the information in this manual is not followed exactly, fire or explosion may result causing property damage, personal injury, or loss of life.

**AVERTISSEMENT.** Assurez-vous de bien suivre les instructions données dans cette notice pour réduire au minimum le risque d'incendie ou d'explosion ou pour éviter tout dommage matériel, toute blessure ou la mort

**⚠ WARNING**

Do not store or use gasoline or other flammable vapors or liquids in the vicinity of this or any other appliance. Installation and service must be performed by a qualified installer, service agency, or the gas supplier.

Ne pas entreposer ni utiliser d'essence ou ni d'autres vapeurs ou liquides inflammables à proximité de cet appareil ou de tout autre appareil.

**WHAT TO DO IF YOU SMELL GAS:**

- Do not try to light any appliance.
- Do not touch any electrical switch; do not use any phone in your building.
- Immediately call your gas supplier from a neighbor's phone. Follow the gas supplier's instructions.

If you cannot reach your gas supplier, call the fire department.

**QUE FAIRE SI VOUS SENTEZ UNE ODEUR DE GAZ:**

- Ne pas tenter d'allumer d'appareil.
- Ne touches à aucun interrupteur; ne pas vous servir des téléphones se trouvant dans le bâtiment.
- Appelez immédiatement votre fournisseur de gaz depuis un voisin. Suivez les instructions de fournisseur.

Si vous ne pouvez rejoindre le fournisseur, appelez le service de incendies.

**⚠ WARNING**

It is essential to read, understand, and follow the recommendations of this manual before installing, operating or servicing this equipment. Failure to do so could result in personal injury or death.

**⚠ WARNING**

Installation and service must be performed by a qualified and knowledgeable individual who has been certified on the P-K HiDRA appliance. The features which permit this appliance to achieve high-efficiency performance can be misused which could result in personal injury or death.

This manual describes the installation and operation for of P-K HiDRA™ series appliances featuring NURO® controls:

**HC800, HC1000:**

- Natural Gas, 120V (single phase), 60 Hertz

**NOTICE!** This manual covers single fuel P-K HiDRA™ appliances.

Individual differences between each appliance model will be called out and defined in separate sections and the titles of these sections will include the appliance model number. If appliance model numbers are not listed in the section title, that section is common to all appliance models.

If you have any questions on the information contained within, or do not fully and completely understand the content, please contact Harsco Industrial Patterson-Kelley Technical Service at **570.476.7261** or toll free at **877.728.5351**.

The P-K HiDRA™ gas-fired appliance is fully modulating using a variable speed combustion blower, sophisticated microprocessor controls, modulating gas safety shut off / control valves and a unique duplex stainless steel heat exchanger capable of operating in a fully condensing mode to provide

maximum efficiency in a minimum amount of space. The high-quality materials and design of the appliance should provide years of trouble-free service if the instructions in this manual are followed carefully.

The appliance is only a part of the complete system. This appliance may be fully operational and yet because of poor circulation, improper control or other site related characteristics, not deliver hot water to the desired location. Additional equipment such as temperature sensors, pumps, flow switches, balancing valves, mixing valves, and check valves will be required for satisfactory operation of any system. Harsco Industrial Patterson-Kelley cannot be responsible for the design or operation of such systems and a qualified engineer or contractor must be consulted.

While details may differ slightly, basic operation is the same for all models. Appliances may be built to operate with natural gas. Check the rating plate for correct fuel usage and gas pressures.

PRELIMINARY DOCUMENT - SUBJECT TO CHANGE

## 1.1 Purpose of this Document

It is the purpose of this Installation and Owner's Manual is to provide complete documentation support for P-K HiDRA appliances featuring NURO controls. Harsco Industrial Patterson-Kelley is constantly seeking ways to produce high quality HVAC products. Our operation is based on the premium quality control program and insures that Harsco Industrial manufactures quality products.

The primary concern of all Harsco Industrial Patterson-Kelley equipment installation procedures is Safety. Safety instructions and considerations are presented and repeated throughout the document as needed. If you have any questions on the information contained within, or do not fully and completely understand the content, please contact Harsco Industrial Patterson-Kelley Technical Service at **570.476.7261** or toll free at **877.728.5351**.

## 1.2 Common Abbreviations

Abbreviation	Description
AMP	Ampere or Amperage
ANSI	American National Standards Institute
ASME	American Society of Mechanical Engineers
AWG	American Wire Gauge
BTU	British Thermal Unit
CO <sub>2</sub>	Carbon Dioxide
CSA	Canadian Standards Association
CSD-1	Controls and Safety Devices
CPVC	Chlorinated Polyvinyl Chloride
DHW	Domestic Hot Water
GPH	Gallons per Hour
HWR	Heating Water Return / Hot Water Return (From Building)
HWS	Heating Water Supply / Hot Water Supply (To Building)
ID	Inside Diameter
MBH	Thousands of BTU / Hour
MODBUS	A serial communication protocol (not an abbreviation)
NFPA	National Fire and Protection Agency
NTC	Negative Temperature Coefficient
O <sub>2</sub>	Oxygen
OD	Outside Diameter
OEM	Original Equipment Manufacturer
SCFM	Standard Cubic Feet per Minute
SMACNA	Sheet Metal and Thermoplastic Duct Construction Manual Air Conditioning Contractors National Association
TB<#>	Terminal Block (1, 2, 3 etc.)
VAC	Volts Alternating Current
VDC	Volts Direct Current

**⚠ WARNING**

Installation and service must be performed by a qualified installer, service agency, or gas supplier. Failure to install the equipment in accordance with this manual could result in an unsafe operating condition.

L'installation et l'entretien doivent être assurés par un installateur ou un service d'entretien qualifié ou par le fournisseur de gaz.

**NOTICE!**

Controls and other equipment that are damaged or fail due to weather exposure are not covered by warranty.

**⚠ WARNING**

The appliance is heavy and requires additional technicians to support and move the unit(s) during installation. Use extreme caution to avoid dropping the appliance or cause any bodily injury while lifting or handling. When positioning this appliance, maintain positive control of it at all times. Do not attempt to move the appliance on surfaces that are not level. Failure to heed this warning could result in personal injury or death.

**NOTICE!**

The appliance may be installed on a combustible floor; however, the appliance must never be installed on carpeting.

**⚠ WARNING**

Bumping hazard from overhead ducts! Install all components with adequate vertical clearances. Insufficient clearance can restrict the service access, increasing the possibility of injury.

## 2 Site Preparation

### 2.1 Initial Inspection upon Receiving

**Upon receiving the appliance, inspect it for signs of shipping damage.** Some damage may be hidden. Unpack the appliance, open the front door to the control panel, and inspect the appliance. Verify that the total number of pieces shown on the packing slip agrees with those received.

**NOTICE!** Note any damage, suspected potential damage, or shortage of materials on the freight bill and immediately notify the carrier. File all claims for shortage or damage with the carrier. Claims for hidden damages must be filed with your carrier within 7 days. The carton is equipped with a "Tip (N) Tell". If the "Tip (N) Tell" arrow point is blue, that indicates the package has been on its side or tipped over in transit.

### 2.2 Storage Prior to Installation

If the appliance is not installed immediately, it must be stored in a location adequately protected from the weather, preferably indoors. If this is not possible, then it should remain in the shipping container and be covered by a tarpaulin or other waterproof covering.

## 2.3 Compliance with Codes

Each P-K HiDRA appliance with standard components complies with American National Standard/CSA Standard ANSI Z21.10.3/CSA 4.3, latest edition for Gas-Fired Water Heaters.

The P-K HiDRA 800, 1000 heat exchangers are constructed and stamped in accordance with ASME Boiler and Pressure Vessel Code, Section IV for 160 psig maximum pressure and 210°F maximum temperature. Other codes or approvals which apply will be labeled on the appliance.

	<b>HC800, HC1000</b>
<b>Code of Construction</b>	ASME Section IV – “HLW” (Latest Edition)
<b>Maximum Allowable Working Pressure</b>	160 PSIG
<b>Maximum Allowable Design Temperature</b>	210° F
<b>Hi-Limit Setpoint</b>	190° F
<b>Maximum Setpoint</b>	180° F

**NOTE**

The P-K HiDRA is in compliance with NSF 61 codes regarding potable water installations.

**NOTE**

Each appliance is supplied with a mechanical Temperature and Pressure relief valve set at 150 psi and 210° F.

Installation of the appliance must conform to all the requirements of all national, state and local codes established by the authorities having jurisdiction or, in the absence of such requirements, to the National Fuel Gas Code, ANSI Z223.1/NFPA 54 latest edition in the U.S. In Canada, the equipment shall be installed in accordance with the current Installation Code for Gas Burning Appliances and Equipment, CAN/CSA-B.149, latest edition, and applicable Provincial Regulations for the class, which should be carefully followed in all cases. Authorities having jurisdiction should be consulted before making any installation.

In the Commonwealth of Massachusetts (a) this unit must be installed by a licensed pipe fitter/plumber, (b) field installed gas cocks must be “T” handle type, (c) piping of condensate shall conform to the State Plumbing Code, and (d) refer to the Massachusetts Supplement for further details.

## 2.4 Location Setup

### 2.4.1 Foundation

The appliance must be installed level, on a housekeeping pad, to function properly. Ensure the base is securely connected to the appliance. Use a bubble level and make sure housekeeping pad is level before installation of water heater. There are four (4) bolts that will be used to secure P-K HiDRA to the housekeeping pad. The housekeeping pad must be at least 6 inches in height.

The appliance should be located in an area where leakage of the tank or connections will not result in damage to the area adjacent to the appliance or to lower floors of the structure. When such locations cannot be avoided, it is recommended that a suitable drain pan, adequately drained, be installed under the appliance. The pan must not restrict combustion air flow.

**NOTE**

Never install appliance on carpeting.

### 2.4.2 Clearances

Failure to provide adequate service clearances, even with non-combustible surfaces, may present problems during routine maintenance of the appliance. The appliance must be installed in a space

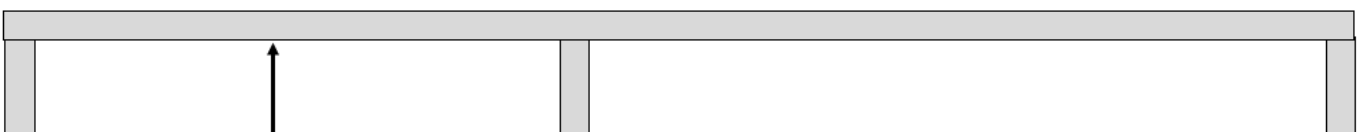



large in comparison to the appliance as described in the National Fuel Gas Code, NFPA 54/ANSI Z223.1, Latest Edition.

Type of Surface	Dimensions (inches)				
	A	B	C	D	E
CSA Minimum Clearances to Combustibles	24	2	12	2	2
Clearance to Non-Combustible Surfaces	0	0	0	0	0
Recommended Service Clearances	24	0*	16	0*	0*

Do not put pipes, ducts, etc. in area above the appliance.

\*Clearance may be subject to local or jurisdictional codes or requirements. Unit may require an elevated service platform or ladder to perform proper maintenance.

**Note:** Failure to provide recommended service clearances may make it difficult to perform service on the appliance(s).

Clearance must be in accordance with local installation codes and the requirements of the gas supplier.

Dégagement conforme aux codes d'installation locaux et aux exigences du fournisseur de gaz.

The minimum clearance to combustible material is 12" from the top, 24" from the front and 2" from the sides and back of the water heater. The HiDRA can be installed directly on a combustible floor.

Distance minimale aux matériaux combustibles est égale à 30.5 cm sur le haut, 61 cm a le derrière, et 5 cm aux les cotes et la derrière. L'appareil peut être installé directement sur un plancher combustible.

Additional clearance beyond the minimum required to combustible materials and other requirements may be required to comply with local, state or national codes and regulations. It is to the responsibility of the installer to comply with these requirements. Examples of codes or regulations that may apply are the National Electric Code, State/Regional/National drain water and flue emissions regulations, the National Fuel Gas Code, Building Construction and Safety Codes, the Americans with Disabilities Act

(ADA) and, in states where a water heater above a certain input or storage capacity is considered a boiler, the applicable boiler code requirements, the applicable boiler installation requirements in “Safety Code for Controls and Safety Devices for Automatically Fired Boilers” (CSD-1) and other regulatory requirements.

## 2.5 Gas Piping Considerations

Before making the gas hook-up, make sure the appliance is being supplied with the type of fuel shown on the appliance nameplate.



Supplying a fuel other than that shown on the appliance’s nameplate can lead to over firing of the appliance. This can cause damage to the equipment which could result in serious injury and/or death.

The appliance shall be installed such that the gas ignition system components are protected from water (dripping, spraying, rain, etc.) during appliance operation and service (circulator replacement, control adjustment, etc.).

## 3 Installation

### 3.1 Overview

For site preparation follow the guidelines established in [Section 2](#). [Section 3](#) details the installation requirements for electrical connections, combustion air, and flue vent piping, hydronic piping, etc.

### 3.2 Appliance Connections

The table below summarizes the appliance connections to the P-K HiDRA series appliances:

Water Heater Model	HC800	HC1000
Power Requirement	110-120/1/60 VAC	
Air Intake Connection	6"	
Nominal Exhaust Vent Connection	6"	
Condensate Drain	3/4" Flexible Tubing	
Heat Exchanger Drain	1" NPT-F	
Natural Gas Shutoff Valve	1" NPT-F	
HWR Connection	2" NPT	
HWS Connection	2" NPT	
Building Recirculation	1" NPT	

### 3.2.1 Water Heater System Guidelines

All connections must be in compliance with national, state, and local code requirements.

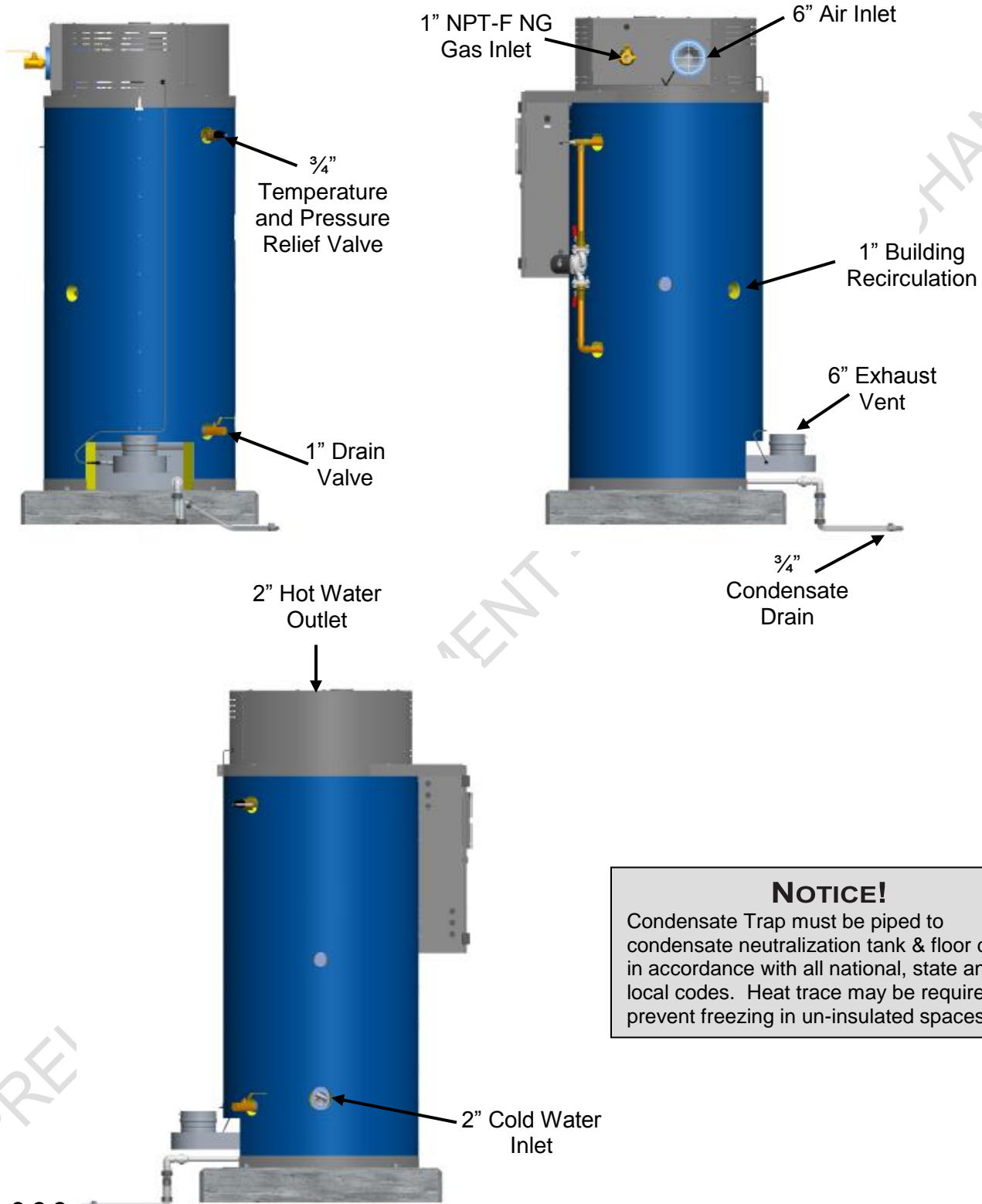

**NOTICE!**  
Condensate Trap must be piped to condensate neutralization tank & floor drain in accordance with all national, state and local codes. Heat trace may be required to prevent freezing in un-insulated spaces.

### 3.2.2 Strainer

To avoid possible contamination of the appliance with dirt, rust or sediment from the system, a strainer near the appliance inlet is strongly recommended. Even new systems may contain sufficient foreign material to eventually reduce the performance of the heat exchanger. Adequate circulation of good clean water is essential for maximum efficiency and long life of the appliance.

### **Relief Valve Piping**

Each appliance is supplied with a pressure and temperature relief valve sized in accordance with ASME requirements. The relief valve discharge must be piped to an acceptable drain at a safe point of discharge. Valves, reducing couplings or other restrictions are not permitted in the discharge line.

### **Low Water Cut-off**

The appliance is furnished with a probe-type low water cut-off; no field piping is required. If the water level in the appliance drops below the probe, the appliance will shut down and LOCKOUT LOW WATER LEVEL will be displayed on the control panel. The low water cutoff circuit will automatically reset when the low water condition clears; the appliance controls will retain the lockout condition until the reset button on the display is depressed. Installation of external limit controls may be required by certain codes or in certain installations. Review applicable local codes for details.

### **Drain Valve and Piping**

A drain valve is factory installed in the tank. Prior to draining the appliance, electrical power and gas supply must be turned off to the appliance, and the appliance must be isolated from the system at the supply and return connections.

If a water heater is installed in a closed water supply system, such as one having a backflow preventer in the cold-water supply line, means shall be provided to control thermal expansion. Contact the water supplier or local plumbing inspector on how to control this situation.

### **NOTICE!**

This drain valve is factory installed for draining of the appliance's water only, not the entire system. Draining of the system through the appliance will result in depositing sediment from the system in the appliance which will result in poor heat transfer characteristics of the appliance and early appliance failure. Not all water will be removed during the drain process.

### **Condensate Drain**

The condensate is acidic (pH between 3.0 and 5.0) and may be corrosive to some building drain systems. A condensate neutralization system may be required and is available from Harsco Industrial Patterson-Kelley.

Disposal of condensate must comply with all state and local codes.

The appliance may generate up to one gallon of condensate per 100,000 BTU input. See table below for typical condensate loading. The condensate should be piped into a neutralization device, and then drained.

#### **Typical Condensate Loading**

<b>HC800</b>	<b>HC1000</b>
8GPH	10GPH

### 3.3 Electrical Connections

#### 3.3.1 Power Requirements

The P-K HiDRA appliances require 110-120 VAC, single phase, 60 hertz electrical service. The 800 requires less than 6 Amps while the 1000 require less than 10 Amps at full load. Before starting the appliance, check to ensure that the proper electrical service is connected to the appliance. Harsco Industrial Patterson-Kelley recommends a minimum circuit capacity of 10 amperes dedicated for the appliance.

An external electrical disconnect and overload protection (not supplied with the appliance) **are required**. Refer to [Section 3.3.6](#) for proper wiring and configuration of the electrical connections. The appliance electrical service must be installed and grounded in accordance with local codes or in the absence of such requirements, in the U.S. with National Electrical Codes, ANSI/NFPA No. 70 latest edition or, in Canada, to the current Canadian Electrical Code, Part I, CSA C22.1 latest edition. Installed conduit must not block any of the appliances' openings and must allow the front door to be opened.

The low voltage (TB1) and high voltage (TB2) terminal boxes are located behind the front door of the appliance. The low voltage (TB1) terminals are the lower set of terminal boxes and the high voltage (TB2) terminals are under the cover in the top left of the control box as shown below:

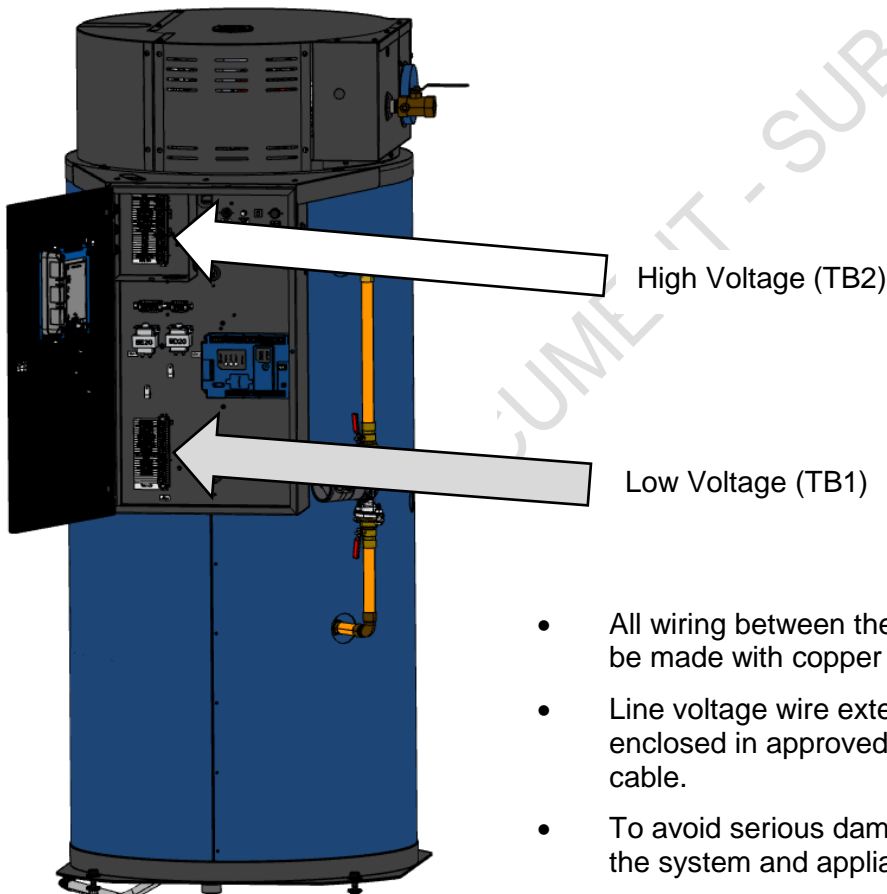

- All wiring between the unit and field installed devices must be made with copper wire.
- Line voltage wire exterior to the appliance must be enclosed in approved conduit or approved metal clad cable.
- To avoid serious damage, DO NOT energize the unit until the system and appliance is full of water.

Tout le câblage entre l'appareil et les appareils installés au bâtiment doit être fait avec du fil de cuivre. Le fil d'énergie extérieur à l'appareil doit être enfermé dans un conduit approuvé ou un câble revêtu de métal. Pour éviter de graves dommages, N'ALIMENTEZ PAS l'appareil d'énergie tant que le système et l'appareil ne sont pas pleins d'eau.

## **CAUTION**

Be sure to check the nameplate on the appliance before connecting the electrical supply.

### **NOTICE!**

A dedicated earth ground (green wire) is required to avoid nuisance shutdowns. Do not ground through the conduit!

## **WARNING**

The high voltage (TB2) terminal block on the HiDRA appliances with NURO controls contains one hot lead (HOT L1), a neutral lead (NEUTRAL) and a ground lead (GROUND) for 120 VAC, single phase 60Hz electrical supply. This terminal block (TB2) also contains dry-contact relays with a maximum voltage rating of 120VAC and 1/2 Amp maximum current capacity. Incorrect wiring can result in equipment damage, injury, or death.

### **3.3.2 High Voltage (TB2) Terminal Block**

**HOT L1** – Connect the hot lead of the 120VAC, single phase, 60Hz electrical service to the TB2-1 terminal.

**NEUTRAL N1** – Connect the neutral lead of the 120VAC, single phase, 60Hz electrical service to the TB2-3 or TB2-4 terminals.

**GROUND G1** – Connect the ground lead from the electrical service to the TB2-5 terminal.

**Start Interlock #2** – The Start Interlock #2 TB2-6 & TB2-7 terminals are in series with Start Interlock #1 and provide additional connection points for auxiliary safety devices. This circuit is energized with 120VAC, so the contacts on any auxiliary safety devices must be rated for minimum 120VAC.

**Start Interlock #1** – The Start Interlock #1 TB2-8 & TB2-9 terminals can be used for auxiliary safety devices such as damper limit switches, control valve limit switches, emergency stop buttons, and low water cutoff devices. This circuit is energized with 120VAC, so the contacts on any auxiliary safety devices must be rated for a minimum of 120VAC.

The appliance ships with a factory-installed jumper across Start Interlock #1 and Start Interlock #2 terminals. Remove the jumper(s) if using any auxiliary safety devices.

#### **NOTE**

Both the Start Interlock #1 and Start Interlock #2 circuits must close within 5 minutes of a call for heat. Failure to close the Start Interlock circuit will cause the appliance to lockout on alarm.

**Auxiliary Input #2** – The TB2-10 & TB2-11 terminals are reserved for future use. This circuit is energized with 120VAC.

**Air Damper Interlock** – The Air Damper Interlock TB2-14 & TB2-15 terminals allow for proof of open end limit switch on a motorized air damper. This circuit is energized with 120VAC, so the contacts on the end limit switch must be rated for minimum 120VAC.

The appliance ships with a factory-installed jumper across the Air Damper Interlock terminals. Remove the jumper if connecting a motorized air damper with end limit switch.

**Ground** – Grounding connection for auxiliary safety/limit devices on terminal TB2-16.

#### **NOTE**

This ground terminal is connected to the TB2 sheet metal and is not common with the appliances electrical service ground.

**Relay B** – User-configurable relay output #2 located on terminals TB2-21 & TB2-22. The normally-open contacts on this relay have a maximum voltage rating of 240VAC and maximum current capacity of 1/2 Amp.

**Relay C** – User-configurable relay output #3 located on terminals TB2-19 & TB2-20. The normally-open contacts on this relay have a maximum voltage rating of 240VAC and maximum current capacity of 1/2 Amp.

**Relay D** – User-configurable relay output #4 located on terminals TB2-17 & TB2-18. The normally-open contacts on this relay have a maximum voltage rating of 240VAC and maximum current capacity of 1/2 Amp.

**NOTE**

Refer to [6 Parts/Technical Support](#) for proper wiring and configuration of the electrical connections.  
 Relays B through C can be user-configured through the NURO touch screen interface to control devices such the Domestic Hot Water (DHW) Pump, Air Damper, Tank Pump, etc. Relay D cannot be used for Air Damper.

**Master Alarm Relay** – The Master Alarm Relay TB2-25 & TB2-26 terminals are normally-open dry contacts that close in the event of an alarm output from the appliance’s control. The normally-open contacts on this relay have a maximum voltage rating of 240VAC and maximum current of 1/2 Amp.

**3.3.3 Low Voltage (TB1) Terminal Block**

**Spare Digital Input A** – The TB1-1 and TB1-2 terminals are reserved for future use.

**4-20mA Analog Input** – The TB1-3 and TB1-4 terminals are reserved for future use.

**Inlet Sensor** – TB1-5 and TB1-6 are reserved for future use.

**Spare Analog Input C** – The TB1-7 and TB1-8 terminals are reserved for future use.

**DHW Stat / Sensor** – TB1-9 and TB1-10 can be used to enable or disable the appliance. The Sensor Input is for future use. The unit ships with a jumper installed across the DHW Stat. Remove the jumper if using the DHW Stat / Sensor input.

**Spare Analog Input D** – The TB1-11 and TB1-12 terminals are reserved for future use.

**Spare Digital Input B** – The TB1-13 and TB1-14 terminals are reserved for future use.

**4-20mA Analog Output** – TB1-15 and TB1-16 provide a 4-20mA analog output signal which tracks the appliance’s firing rate. When operating at full power (maximum firing rate), the appliance will provide a 20mA output. When operating at minimum power (minimum firing rate), the appliance will provide a 4mA output.

**Ground** – TB1-17 provides an equipment (frame) ground connection for input, output, or communication connections. For independently powered control devices, it may be necessary to create a common ground.

**MODBUS COM & MODBUS Shield** – TB1-22, TB1-23 and TB1-24 can be used to integrate the appliance with a Building Management System (BMS), Protocol Converter, or other device capable of RS-485 2-wire MODBUS communication. Terminals TB1-22 and TB1-23 are reserved for MODBUS and terminal TB1-24 provides a connection for the MODBUS communication wire shield.

**NOTE**

Only ground the shield at the master appliance.

**3.3.4 Terminal Block Assignments — Low Voltage (TB1) Terminal Block**

Terminal Number	Label	Description
-----------------	-------	-------------



1	Spare Digital Input A	Reserved for Future Use
2	Spare Digital Input A	
3	4-20mA Analog Input [ + ]	Reserved for Future Use
4	4-20mA Analog Input [ + ]	
5	WATER INLET TEMP	External Inlet Sensor
6	WATER INLET TEMP	
7	Spare Analog Input C	Reserved for Future Use
8	Spare Analog Input C	
9	DHW STAT / Sensor	DHW Enable Circuit
10	DHW STAT / Sensor	
11	Spare Analog Input D	Reserved for Future Use
12	Spare Analog Input D	
13	Spare Digital Input B	Reserved for Future Use
14	Spare Digital Input B	
15	4-20mA ANALOG OUTPUT [ + ]	4-20mA Analog Output Tracks Appliance Firing Rate 100% Firing Rate = 20mA, 1% Firing Rate = 4mA
16	ANALOG OUTPUT [ - ]	
17	GROUND	Ground Terminal for I/O Devices
18	CASCADE SHIELD	Reserved for Future Use
19	CASCADE A TO A	
20	CASCADE B TO B	
21	MODBUS/CASCADE REF	2-Wire MODBUS
22	MODBUS COM A	
23	MODBUS COM B	MODBUS Shield Terminal
24	MODBUS SHIELD	

### 3.3.5 Terminal Block Assignments — High Voltage (TB2) Terminal Block

Terminal Number	Label	Description
1	HOT L1	L1 for 110-120VAC, Single phase, 60Hz
2	<b>N/A</b>	<b>N/A</b>
3	NETURAL N1	N1 for 110-120VAC, Single phase, 60Hz
4	NEUTRAL N1	
5	GROUND G1	G1 for 110-120VAC, Single phase, 60Hz
6	START INTERLOCK #2	External Interlock Circuit #2 (In Series w/ #1) (110-120VAC, Single phase, 60Hz)
7	START INTERLOCK #2	
8	START INTERLOCK #1	External Interlock Circuit #1 (110-120VAC, Single phase, 60Hz)
9	START INTERLOCK #1	
10	AUXILIARY INPUT #2	Reserved for Future Use
11	[120V+] AUXILIARY INPUT #2	
12	<b>N/A</b>	<b>N/A</b>
13	<b>N/A</b>	
14	AIR DAMPER INTERLOCK	120VAC Pilot-Duty for Air Damper End Limit Switch Contact Closure When Air Damper Proven Open
15	[120V+] AIR DAMPER	
16	GROUND	Ground Terminals for I/O Devices
17	RELAY D	User-Configurable Normally-Open Dry Contact D (240VAC Max Voltage & 1/2Amp Max Current)
18	RELAY D	
19	RELAY C	User-Configurable Normally-Open Dry Contact C (240VAC Max Voltage & 1/2Amp Max Current)
20	RELAY C	
21	RELAY B	User-Configurable Normally-Open Dry Contact B (240VAC Max Voltage & 1/2Amp Max Current)
22	RELAY B	
23	<b>N/A</b>	<b>N/A</b>
24	<b>N/A</b>	
25	MASTER ALARM RELAY	Normally-Open Dry Contact, Close on Alarm (240VAC Max Voltage & 1/2Amp Max Current)
26	MASTER ALARM RELAY	

### 3.3.6 Wiring Diagram

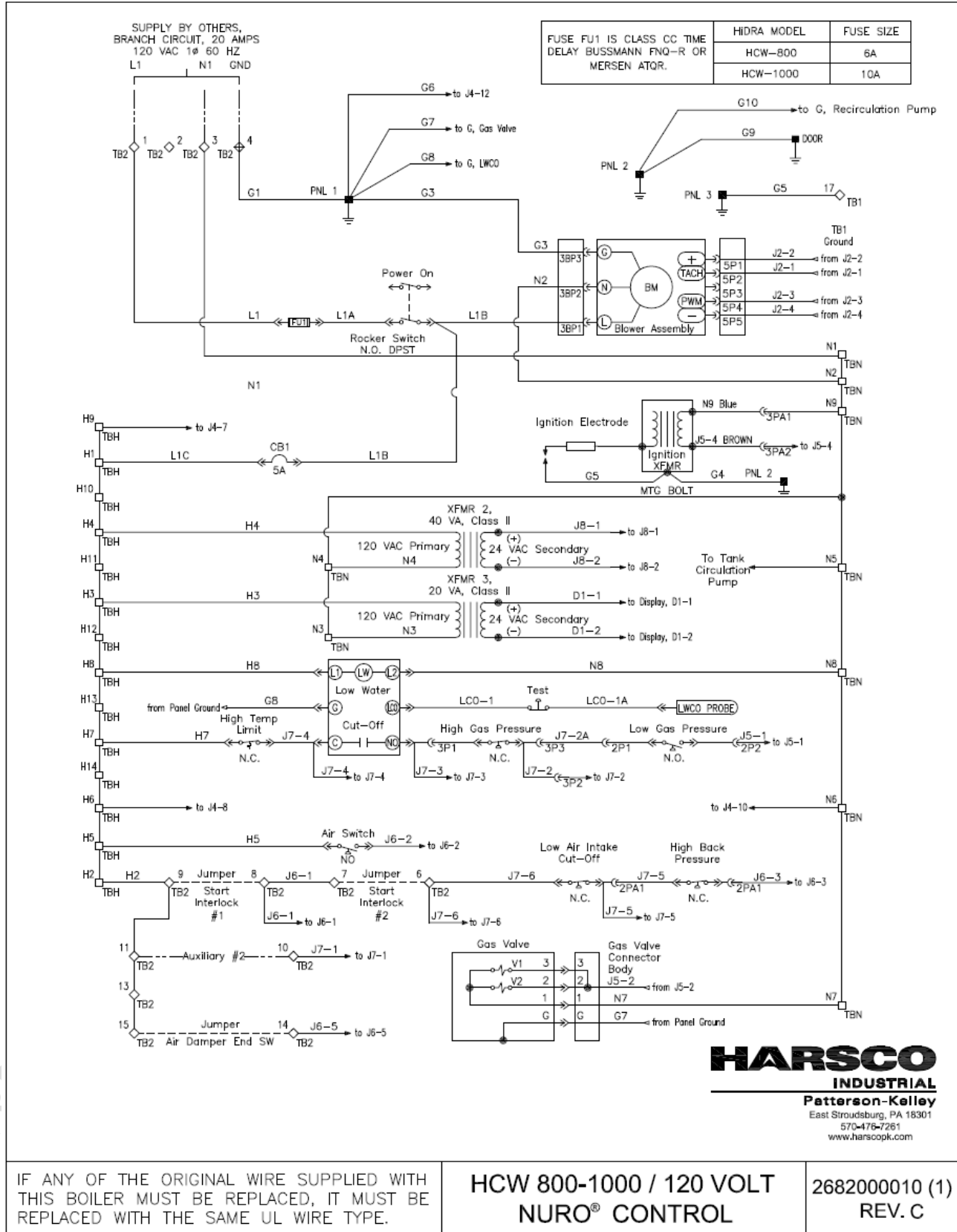

IF ANY OF THE ORIGINAL WIRE SUPPLIED WITH THIS BOILER MUST BE REPLACED, IT MUST BE REPLACED WITH THE SAME UL WIRE TYPE.

HCW 800-1000 / 120 VOLT  
NURO® CONTROL

2682000010 (1)  
REV. C

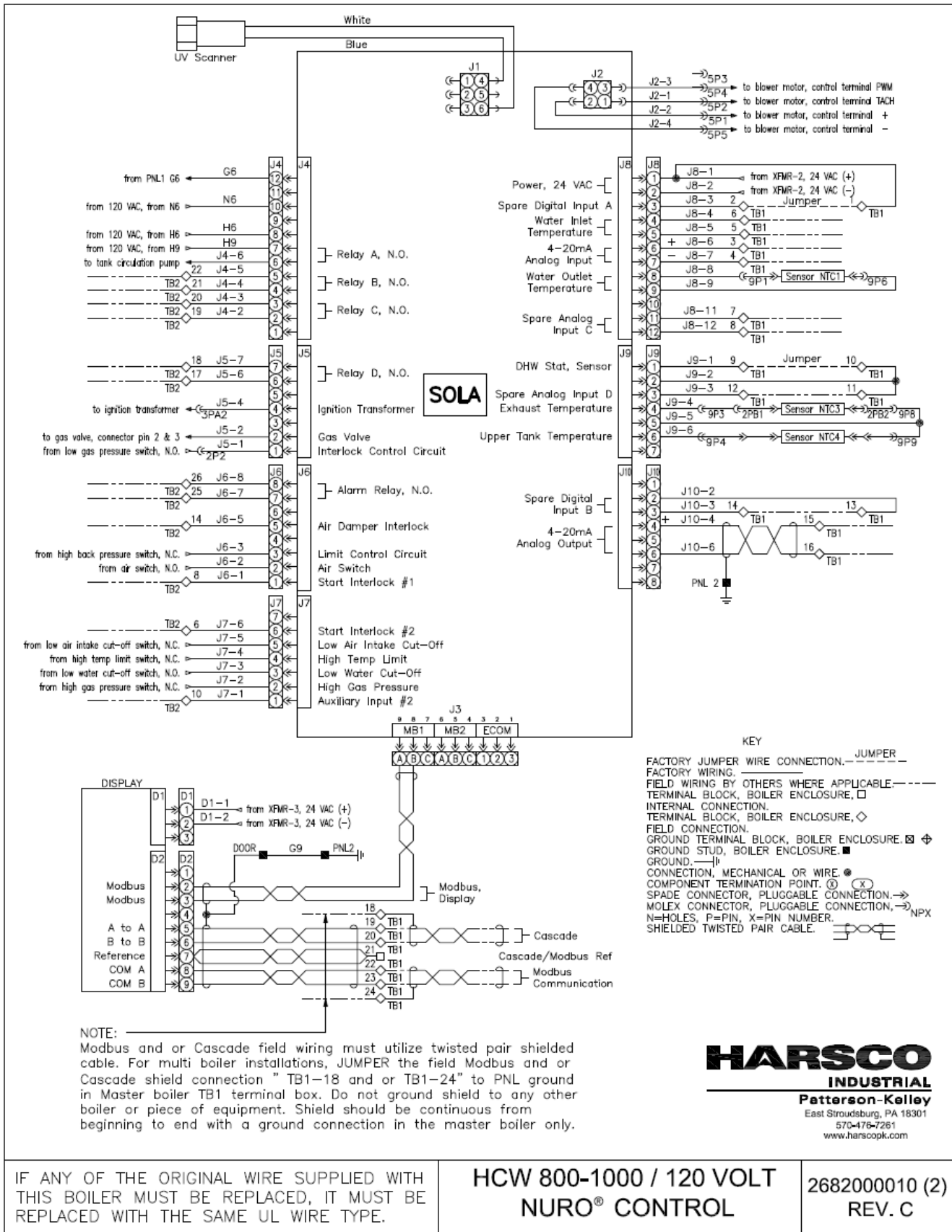

## **⚠ WARNING**

Design and installation of venting systems should be done only by qualified and knowledgeable venting systems personnel and in accordance with vent system manufacturer's installation instructions. Installing an appliance or vent system using improper installation methods or materials can result in serious injury or death due to fire or asphyxiation.

## **⚠ WARNING**

Before connecting an appliance to a venting system, it must be determined whether the appliance is to be installed in a conventional or direct vent configuration. In the US, provisions for combustion air must be in accordance with NFPA 54/ANSI Z223.1, National Fuel Gas Code, latest edition, or applicable provisions of local building codes. In Canada, combustion and ventilation air openings shall comply with CAN/CSA B-149.1 Natural Gas and Propane Installation Code.

## **⚠ WARNING**

For correct installation of a vent system, read all of these instructions and refer to the vent manufacturer's instructions.

Failure to use a proper vent system (types and materials), as described in this manual will void the appliance warranty and may result in rapid deterioration of the venting system, creating a health or life safety hazard. Faulty vent installation can allow toxic fumes to be released into living areas. This may cause property damage, injury, or death.

## 3.4 Inlet Air and Exhaust Venting Considerations

### 3.4.1 Applicable Codes and Standards

#### United States Installation Codes:

NFPA 54/ANSI Z223.1	National Fuel Gas Code
NFPA/ANSI 211	Chimneys, Fireplaces, Vents and Solid Fuel Burning Appliances

#### Canada Installation Codes:

CAN/CSA B149.1	Installation Codes for Gas Burning Equipment
----------------	--

#### Flue Gas Exhaust Vent Standards:

UL 1738	Venting Systems for Gas-Burning Appliances, Categories II, III and IV
ULC S636-95	Standard for Type BH Venting System Sheet Metal and Thermoplastic Duct Construction Manual Air Conditioning Contractors National Association (SMACNA)

These codes and standards contain information for the venting of gas fired appliances, including, but not limited to vent sizing, location, clearance to combustibles, and safe installation practices. The installation must comply with both the above Federal Codes and with state, provincial and local codes.

### 3.4.2 Combustion Air Inlet Planning (United States and Canada Considerations)

- Air inlet requirements for the U.S. are established by NFPA 54/ANSI Z223.1 & NFPA/ANSI 211.
- Air inlet requirements for Canada are established by CAN/CSA B149.1.

Refer to [Section 3.5](#), for more details on combustion air inlet requirements in the United States and Canada.

### 3.4.3 Category II/IV Flue Gas Exhaust Vent Planning

Several codes and standards have categorized appliances in accordance with the flue gas temperature and pressure produced by the appliance. The applicable categories are defined as follows:

- **Category II:** An appliance that operates with a non-positive vent static pressure and with a vent temperature that may cause excessive condensate production in the vent.
- **Category IV:** An appliance that operates with a positive vent static pressure and with a vent temperature that may cause excessive condensate production in the vent.
- **Direct Vent:** An appliance that is constructed and installed so that all air for combustion is derived directly from outdoors and all flue gases are discharged to the outdoors.

All P-K HiDRA appliances are dual-certified as **Category II or IV**, as defined in ANSI Z21.13/CSA 4.9, latest edition. The P-K HiDRA series appliances are capable of operating with slightly negative to slightly positive exhaust pressure. It is critical to ensure the flue vent material is certified for **Category II or IV** operation.

**NOTE:** For **Category II** installations, ensure the flue venting system is designed to maintain a slightly negative exhaust pressure **between -0.01" W.C. and -0.05" W.C.**

**NOTE:** For **Category IV** installations, ensure the flue venting system is designed to maintain a slightly positive exhaust pressure which **MUST BE** in the following ranges:

- **+0.01" W.C. and +0.5" W.C. (Direct Vent / Sealed Combustion)**
- **+0.01" W.C. and +1.0" W.C. (Exhaust Only)**

The vent material to be used for US and Canada is listed in the Table of Acceptable Materials for Venting Systems located in [3.4.4](#).

Vent installations shall be in accordance with NFPA 54/ANSI Z223.1, the National Fuel Gas Code, or CAN/CSA-B149.1, the Natural Gas and Propane Installation Code, or applicable provisions of the local building codes.

#### Vent Sizing for Category II / IV Operation

The vent must be sized in accordance with the ASHRAE Systems and Equipment handbook (Chapter 30) or according to the vent manufacturer's recommendations. When using manufactured venting systems, consult your vent supplier for correct sizing and structural support requirements.

P-K HiDRA Appliance Model	Draft	Stack Temperature	CO <sub>2</sub> Natural Gas
HC800/HC1000	Category II -0.01" to -0.05" W.C.	220 °F (gross)	9.5%
HC800/HC1000	Category IV (Sealed Combustion) +0.01" to +0.5" W.C.	220 °F (gross)	9.5%
HC800/HC1000	Category IV (Exhaust Only) +0.01" to +1.0" W.C.	220 °F (gross)	9.5%

### 3.4.4 Venting Materials for Flue/Exhaust Systems

The P-K HiDRA appliances are dual certified as **Category II** and **Category IV** appliances, which vent with a temperature that is likely to cause condensation in the vent. Therefore, any venting system used with the P-K HiDRA appliance must comply with the requirements for either Category II or Category IV venting systems as specified in the latest edition of NFPA 54/ANSI Z223.1 in the US or the latest edition of CAN/CSA B-149.1 in Canada.

#### CPVC Venting

**US:** CPVC pipe conforming to ASTM F441. Sch 80 fittings conforming to ASTM F439. Joints are to be sealed with solvent conforming ASTM 493.

**Canada:** CPVC Pipe, Fitting and Sealant listed and labeled to ULC S-636 Standard for Type BH Venting Systems.

#### Polypropylene Venting

**US and Canada:** Polypropylene such as InnoFlue® from Centrotherm. When used, the same manufacturer's material must be used throughout the system. It is not permissible to use material from different manufacturers within the same system.

#### As per ANSI Z21.13b-2012 \* CSA 4.9b-2012:

- The use of cellular core PVC, CPVC and Radel® as venting materials is prohibited.
- The use of external insulation on plastic vent pipe is prohibited.

#### Acceptable Venting Materials

Model	Country	AL29-4C	316L SS	PVC	CPVC	POLYPROPYLENE
HC800	US	Yes	Yes	No	Yes	Note 2
HC1000	US	Yes	Yes	No	Yes	Note 2
HC800	Canada	Yes	Yes	No	Note 1	Note 1
HC1000	Canada	Yes	Yes	No	Note 1	Note 1

### **WARNING**

The venting materials listed are intended for the venting of gas burning appliances only. Do not use these venting materials for venting liquid or solid fuel (such as oil, kerosene, wood or coal) appliances.

The water heater shall not be connected to a chimney flue servicing a separate appliance, designed to burn solid fuel.

Maintain clearances to combustibles as listed in the vent manufacturer's installation instructions or as set forth in the codes and standards listed in this section.

Do not use these vent pipes for incinerators of any sort!

This appliance is not certified for use with PVC venting. Use of PVC venting may result in vent failure and possible serious injury or death.

#### NOTE 1:

When this material is used for venting, it must be listed to ULC-S636.

#### NOTE 2:

When this material is used for venting, it must be listed to UL-1738 (or local authority).



### 3.4.5 Required Clearances

#### Conventional Vent Systems Clearances

The following termination clearance requirements are for conventional non-direct vent installations:

- The vent system shall terminate at least 3 ft. above a forced air inlet located within 10 ft. horizontally.
- The vent system shall terminate at least 4 ft. below, 4 ft. horizontally from or 1 ft. above any door, operable window or gravity inlet into any building. The bottom of the vent terminal shall be at least 12 in. above grade or highest expected snow line (if applicable).
- Through the wall terminations shall not terminate over public walkways, near soffit vents or crawl space vents, or over an area where condensate or vapor could create a nuisance or hazard or could be detrimental to the operation of regulators, relief valves, or other equipment.

#### Direct Vent (Sealed Combustion) Systems Clearances

- The vent terminal shall be located at least 12 in. from any air opening into a building. The bottom of the vent terminal shall be at least 12 in. above grade. Both the vent and air intake terminals must be at least 12 in. above the highest expected snow line.
- Through the wall terminations shall not terminate over public walkways, near soffit vents or crawl space vents, or over an area where condensate or vapor could create a nuisance or hazard or could be detrimental to the operation of regulators, relief valves or other equipment.
- When multiple direct vent appliances are adjacent, the exhaust must terminate at least 10 ft. horizontally or 3 ft. vertically from the air intake of another appliance.

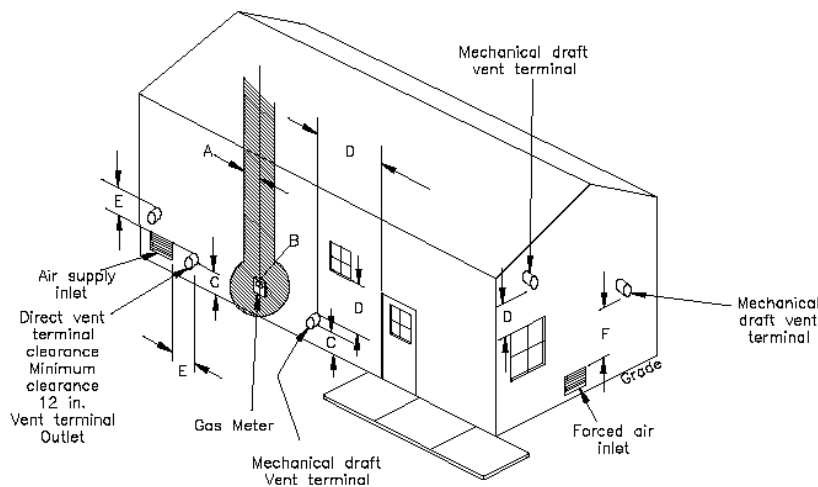

Reference: NFPA 54/ANSI Z223.1 National Fuel Gas Code

#### **WARNING**

The appliance vent should not be connected into any portion of another mechanical draft system without consulting the vent manufacturer. The appliance shall not be connected to any part of a vent system serving a Category I appliance, nor shall a Category I appliance be connected to any part of the vent system serving this appliance. Common venting is prohibited on these P-K HiDRA appliance models. Improper interconnection of venting systems may result in leakage of flue gases into occupied spaces.

#### **NOTE**

The condensate formed from combustion flue gases is acidic. The condensate shall be drained in accordance with local code requirements. A condensate neutralizer may be required by local code.

Mark	Description	US Installations	Canadian Installations
A	Clearance to each side of center line extended above meter/regulator		3 ft. (91 cm) within a height of 15 ft. (4.6 m) above the meter/regulator assembly
B	Clearance to service regulator vent outlet		3 ft. (91 cm)
C	Clearance above grade, porch, deck, veranda, or balcony	12 in	
D	Clearance to window or door that may be opened	4 ft. (1.2 m) below or to side of opening 1 ft. (300 mm) above opening	6 in (15 cm) for appliances ≤ 10,000 Btuh (3 kW) 12 in (30 cm) for appliances > 10,000 Btuh (3 kW) and ≤ 100,000 Btuh (30 kW) 36 in (91 cm) for appliances > 100,000 Btuh (30 kW)
E	Clearance to non-mechanical air supply inlet to building or the combustion air inlet to any other appliance	4 ft. (1.2 m) below or to side of opening 1 ft. (300 mm) above opening	6 in (15 cm) for appliances ≤ 10,000 Btuh (3 kW) 12 in (30 cm) for appliances > 10,000 Btuh (3 kW) and ≤ 100,000 Btuh (30 kW) 36 in (91 cm) for appliances > 100,000 Btuh (30 kW)
F	Clearance to a mechanical air supply inlet	3 ft. (91 cm) above if within 10 ft. (3 m) horizontally	6 feet (1.83 m)
For clearances not specified maintain clearance in accordance with local installation codes and the requirements of the gas supplier			

### Interior Component Clearances

Material	Combustible	Non-Combustibles
Unlisted single wall metal pipe	Do NOT Use	Do NOT Use
Single wall PVC pipe	Do NOT Use	Do NOT Use
UL 1738 listed Category IV vent	Per manufacturer's listing	Per manufacturer's listing

### Flue Connection

The connection from the appliance to the vent should be as direct as possible and the upward slope of any horizontal breaching should be at least 1/4 inch per linear foot. The complete exhaust with drain system is shown in [Section 3.6](#). The appliance connector should incorporate provisions to drain condensate formed in the vent system. The connector should include an appropriate drain section (not provided).

### Combining Vents

1. Combined HiDRA Category IV gas vent systems must incorporate a variable speed, modulating, mechanical draft inducer capable of maintaining the appropriate negative draft at the end of the common flue, to assure that all water heaters in the combined vent system operate with a negative draft. All vent systems shall be approved by a certified engineered venting manufacturer.
2. Combining the exhaust vents of multiple HiDRA condensing water heaters into a common, unpowered or "gravity" vent is never recommended (i.e. venting as Category II). HiDRA water heaters are too efficient and the flue products are too cold to generate the natural buoyancy required for such combined vent systems to function reliably and safely.
3. The common mechanical draft vent system must be interlocked, so the water heaters will not begin operation until the common mechanical draft vent system negative pressure is proved to be within the range approved by a certified engineered venting manufacturer.

When combining the exhausts of multiple HiDRA water heaters, do not use individual remote ducts to provide outdoor combustion air.

4. When exhaust vents are combined, it is necessary to install an air inlet damper on each appliance and either
  - a. Draw all combustion air for each heater from the mechanical room in which they are installed or,
  - b. Use a common air supply system that is designed and installed by a qualified professional firm and that meets all the requirements of a certified engineered venting manufacturer.

**⚠ WARNING**

Do not connect multiple water heaters vents into a single unpowered or fixed speed powered vent. This could cause unsafe operation and the potential for poisonous carbon monoxide to enter occupied areas. Such improper installation can cause property damage, exposure to hazardous materials, personal injury or death.

**NOTE**

Damper must be in open position when appliance main burner is operating.  
Le registre doit être ouvert lorsque le brûleur principal de l'appareil fonctionne.

### 3.5 Combustion Air

#### 3.5.1 Air Inlet Requirements – United States

Air inlet requirements for the United States are established by NFPA 54/ANSI Z223.1 & NFPA/ANSI 211.

When air is supplied from inside the building, the total required volume shall be the sum of the required volume for all the appliances located in the mechanical room. Adjacent rooms furnished with fixed openings communicating directly with the mechanical room are considered part of the required volume. The minimum volume is 50 ft<sup>3</sup> per 1,000 Btu/Hr (4.8 m<sup>3</sup>/kW) of installed appliance input capacity.

Openings used to connect indoor spaces to obtain the required minimum volume shall be sized as follows:

**⚠ WARNING**

**Under no circumstances shall room where the appliance is located ever be under a negative pressure. Particular care should be taken when exhaust fans, compressors, air-handling units or other equipment may rob air from the appliance. Note that this equipment might be in rooms other than where the appliance is located. This applies to both sealed combustion and atmospheric room combustion air applications.**

- When rooms are on the same floor, each opening shall have an area equal to 1 square inch for each 1,000 Btu/Hr (2,200 mm<sup>2</sup>/kW) of installed appliance input capacity, but not less than 100 square inches. One opening should commence less than 12 inches above the floor and the other less than 12 inches below the ceiling. The minimum dimension of air openings shall be 3 inches.
- When rooms are on different floors, each opening shall have an area equal to 2 square inches for each 1,000 Btu/Hr (4,400 mm<sup>2</sup>/kW) of installed appliance input capacity.

When combustion air is supplied from outside the building, the appliance's room shall be provided with one or two openings to ensure adequate combustion air and proper ventilation. When using one permanent opening, the opening shall commence within 12 inches of the ceiling and shall communicate directly with the outdoors or through a vertical or horizontal duct that communicates to the outdoors.

When using two permanent openings, one opening shall commence within 12 inches above the floor and the other within 12 inches below the ceiling, preferably on opposite walls. The openings shall communicate directly, or by way of ducts, with free outdoor air. The minimum net free area of the openings shall be calculated in accordance with the following:

- When air is taken directly from outside the building, each opening (minimum of two, as outlined above), 1 square inch for each 4,000 Btu per hour (550 mm<sup>2</sup>/kW) of total appliance input is required.
- When air is taken from the outdoors through a vertical duct into the mechanical room, 1 square inch per 4,000 Btu per hour (550 mm<sup>2</sup>/kW) of total appliance input is required.
- When air is taken from the outdoors through a horizontal duct into the mechanical room, 1 square inch per 2,000 Btu per hour (1,100 mm<sup>2</sup>/kW) of total appliance input is required.

**US Minimum Area of Intake Openings per Boiler (Sq In)**

P-K HiDRA™ Water Heater MODEL	AIR SOURCE						Supply Air Limits (" W.C.)
	INDOOR AIR SUPPLY		OUTDOOR AIR SUPPLY				
	SAME FLOOR	DIFF FLOORS	ONE OPENING	TWO OPENINGS			
				DIRE CT	VERT DUCT	HORIZ DUCT	
HC800	800	1600	267	200	200	400	0.0-0.25
HC1000	1000	2000	334	250	250	500	0.0-0.25

**NOTE**

1. The required size of openings for combustion and ventilation air shall be based on the net free area of the opening.
2. Screens shall be not smaller than ¼ inch.
3. Motorized louvers shall be interlocked with the appliance so that they are proven open prior to main burner ignition and operation.

### 3.5.2 Air Inlet Requirements – Canada

Air inlet requirements for Canada are established by CAN/CSA B149.1. Ventilation of the space occupied by fuel burning appliance(s) or equipment shall be supplied by a ventilation opening at the highest practicable point communicating with the outdoors. The total cross sectional area of the ventilation opening must be either 10% of the net free area required for combustion air or 10 sq. in. (6,500 mm<sup>2</sup>), whichever is greater.

- A. Ventilation of the space occupied by fuel burning appliance(s) or equipment shall be supplied by a ventilation opening at the highest practicable point communicating with the outdoors. The total cross sectional area of the ventilation opening must be either 10% of the net free area required for combustion air or 10 sq. in. (6,500 mm<sup>2</sup>), whichever is greater.
- B. Use the following opening calculation for P-K HiDRA appliances:  
When combustion air is supplied for a forced draft burner by natural airflow from the outdoors and there is no draft regulator or draft hood in the same space, there shall be a permanent opening with a cross sectional area not less than 1 sq. in./30,000 Btu/Hr (70 mm<sup>2</sup>/kW) of the total rated input to the burner(s). This opening must not interfere with the ventilation air opening defined in **Paragraph A**.
- C. When combustion air is supplied by natural airflow into a space containing both types of appliance described in **Paragraphs B**, the cross sectional area of the opening shall not be less than the sum of the cross sectional areas for all appliances in the space as calculated by the applicable method. This opening is in addition to the ventilation air opening defined in **Paragraph A**.
- D. When a duct is used to meet the requirement for combustion air supply, as described in **Paragraphs A through C**, above, the opening of the duct shall be located so there is no possibility of cold air affecting steam or water piping, electrical equipment or mechanical equipment.
- E. When combustion air is supplied by mechanical means, an airflow-sensing device must be installed. It must be wired into the pre-ignition limit interlock circuit to prevent the burner from starting or to stop an operating burner in case of air supply failure.
- F. When all combustion air is supplied through a make-up air heater, and the appliance is interlocked to the heater, the requirements of **Paragraphs A through E** do not apply.

#### Canadian Minimum Area of Combustion and Intake Air Openings

P-K HiDRA Model #	BTU/Hr Input	Required Combustion Air Opening		Ventilation Air Opening		Supply Air Limits (" W.C.)
		in <sup>2</sup>	mm <sup>2</sup>	in <sup>2</sup>	mm <sup>2</sup>	
HC800	800,000	27	17,419	10	6,452	0.0-0.25
HC1000	1,000,000	33	21,483	10	6,452	0.0-0.25

#### NOTE

1. The free area of a combustion air supply opening is calculated by deducting the blockage area of any fixed louvers, grilles or screens from the total area of the opening.
2. Screens shall be not smaller than ¼ inch.
3. Motorized louvers shall be interlocked with the appliance so that they are proven open prior to main burner ignition and operation.

### 3.5.3 P-K HiDRA™ Combustion Air Requirements

The table below summarizes the combustion air requirements for P-K HiDRA™ water heaters:

P-K HiDRA™ Model #	Air Intake Connection	Required SCFM Combustion Air
HC800	6"	187
HC1000	6"	233

### 3.5.4 Flue Venting Installation

The P-K HiDRA series appliances are certified for operation in direct vent / sealed combustion systems, which feature combustion air intake ductwork which sources the combustion air supply from outdoors. The flow of combustion air through this ductwork is maintained by the appliance's combustion blower.

The combustion air intake ductwork can be constructed with PVC, CPVC, single wall galvanized steel, or other suitable materials. The ductwork must be rigid enough to maintain the full required cross-sectional area under all operating conditions.

**NOTE:** The combustion air intake ductwork must be sufficiently rigid in order to prevent collapse due to the potential for negative pressures inside the ductwork. If the ductwork collapses, this will restrict the combustion air supply to the appliance which may prohibit operation.

Proper sealing of the combustion air intake ductwork is necessary to prevent infiltration of air from conditioned space. For example, joints in PVC or CPVC piping must be cemented. For galvanized duct, wrap each joint and seam with adhesive aluminum tape or other sealant. Harsco Industrial Patterson-Kelley recommends installing a 1" x 1" or larger bird screen on the exterior termination. Ensure that the screen does not become blocked with snow, ice, insects etc.

The combustion air supply must be free from dust, lint, etc. The presence of such materials in the air supplied to the burner could cause nuisance "Low Air" shutdowns or premature burner failure. The appliance should not be operated during construction while the possibility of drywall dust, demolition dust, etc. exists.

The combustion air supply must be completely free of chemical fumes which may be corrosive when burned in the appliance. Common chemicals which must be avoided are fluorocarbons and other halogenated compounds, most commonly present as refrigerants or solvents, such as Freon®, trichloroethylene, perchloroethylene, chlorine, etc. These chemicals, when burned, cause improper combustion and premature appliance failure due to the formation of acids which quickly attack the heat exchanger and the flue piping materials.

## 3.6 Flue Gas / Exhaust Venting

All vent installations shall be in accordance with NFPA 54/ANSI Z223.1, the National Fuel Gas Code, or CAN/CSA-B149.1, the Natural Gas and Propane Installation Code, or applicable provisions of the local building codes.

The vent material to be used for US and Canada is listed in the Table of Acceptable Materials for Venting Systems located in [3.4.4](#).



For interior clearance requirements, refer to [3.4.5](#). The vent shall extend at least three (3) feet above the roof, or at least two (2) feet above the highest part of any structure within ten (10) feet of the vent. This is illustrated in the following diagram. Additionally, the appliance vent shall terminate at least three (3) ft. above a forced air inlet located within ten (10) ft.

To prevent the possible re-circulation of flue gases, the vent designer must take into consideration such things as prevailing winds, eddy zones, building configurations, etc. **Harsco Industrial Patterson-Kelley cannot be responsible for the effects such adverse conditions may have on the operation of the appliances.**

The dimensions listed are minimums and may not be sufficient for conditions at a specific job site. Vertical vents are allowed to be terminated with a variety of ends, including plain straight pipe, elbow or vent tee. Horizontal vents must be terminated with an elbow or vent tee. Similarly, a bird screen with 1" x 1" openings is recommended for termination. Harsco Industrial Patterson-Kelley does not recommend using a vent rain cap of any type.

### 3.6.1 Category II Installations

The HiDRA appliances are dual-certified for either Category II or Category IV operation. Category II appliances operate with a non-positive vent static pressure and with a vent temperature that may cause excessive condensate production in the vent. There are several requirements for reliable operation of the appliances under Category II conditions:

1. A stainless steel vent adapter is required to mate the appliance exhaust connection and the vent pipe. See the table below for the applicable part numbers.
2. A normally-closed motorized damper is required on the appliances' air intake. See the table below for the applicable part numbers.
3. Ensure the flue venting system is designed to maintain a slightly negative draft, measured inside the vent at the rear of the appliance, **between -0.01" W.C. and -0.05" W.C.** Excessive negative draft will cause nuisance trips such as flame failures.
4. The vent system must be properly drained of condensate before returning to the appliance. See [3.2.2](#) for information on installing condensate drains in the exhaust vent.

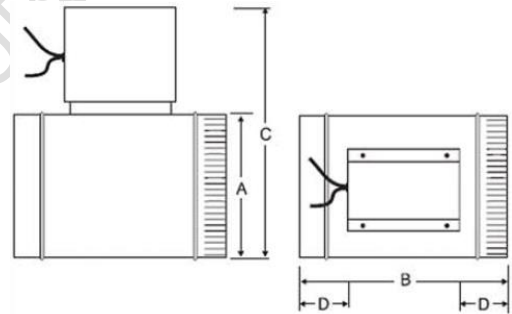

**Table of Required Category II Motorized Dampers**

Water Heater Size	Nominal Stack Size	Normally-Closed Motorized Damper	A	B	C	D
HC800	6"	1004906943	6"	6"	9"	1.38"
HC1000	6"	1004906943	6"	6"	9"	1.38"

The normally-closed motorized damper operates on 120 VAC and features an end limit switch wired into the appliance's air damper interlock circuit. Upon a call for heat, the appliance's damper relay will energize and drive the damper open. Once the damper reaches the fully-open position, the end limit switch makes contact and closes the air damper interlock circuit allowing the appliance to fire. The diagram below shows the wiring necessary to install the normally-closed motorized damper.

Other damper motor voltages are acceptable, provided they do not exceed 240VAC. The Air Damper Interlock circuit for the end limit switch is always 120VAC which is sourced from the appliance itself. All end limit switches must be rated for a minimum 120VAC.



**NOTE**

The above venting criteria equates to properly installed exhaust venting systems consisting of Polypropylene or other approved venting materials in the total amount of two hundred fifty (250) total **equivalent feet** of 6" duct. The resistances of all exhaust vent fittings and installed piping must be considered in the total calculation.

All venting installations are dependent upon, but not limited to: proper design and installation criteria, building pressure considerations, weather / atmospheric conditions, and relative humidity.

Under no circumstances shall the venting criteria be deemed the sole factor of failure in the event of an excessive back pressure venting fault. A situation of correctly installed venting will not preclude the venting pressure limitation required for proper operation.

**Vent Pipe Fittings Equivalent Lengths**

<b>Vent Pipe</b>	<b>Polypropylene 6" Vent</b>	<b>Stainless Steel 6" Vent</b>
90° Elbow	22 feet	20 feet
90° Long Radius Elbow	14 feet	12 feet
45° Elbow	14 feet	12 feet

PRELIMINARY DOCUMENT - SUBJECT TO CHANGE

## ⚠ WARNING

For correct installation of a vent system, read all of these instructions and refer to the vent manufacturer's instructions.

Failure to use a proper vent system (types and materials), as described in this manual will void the appliance warranty and may result in rapid deterioration of the venting system, creating a health or life safety hazard.

Faulty vent installation can allow toxic fumes to be released into living areas. This may cause property damage, injury, or death.

Motorized dampers must be powered from an external power supply other than the appliance. The figure below shows a sample installation in which Relay C is user-selected to operate a 120VAC motorized air damper. Relay C is normally-open, so when the appliance is in standby, the combustion air damper remains closed. Once a call for heat is received, Relay C closes the 120VAC circuit (external power supply) which provides power to the damper motor, opening the damper.

Once the motorized damper is fully-open, its end limit switch completes the Air Damper Interlock circuit (120VAC) which allows the appliance to proceed to ignition.

## ⚠ WARNING

External power supplies are required for Relay B, and Relay C. Because power is provided from an external source, the power is still present when the appliance is turned off. Check all voltage sources have been disconnected prior to servicing. Failure to do so could result in electrocution, injury, or death.

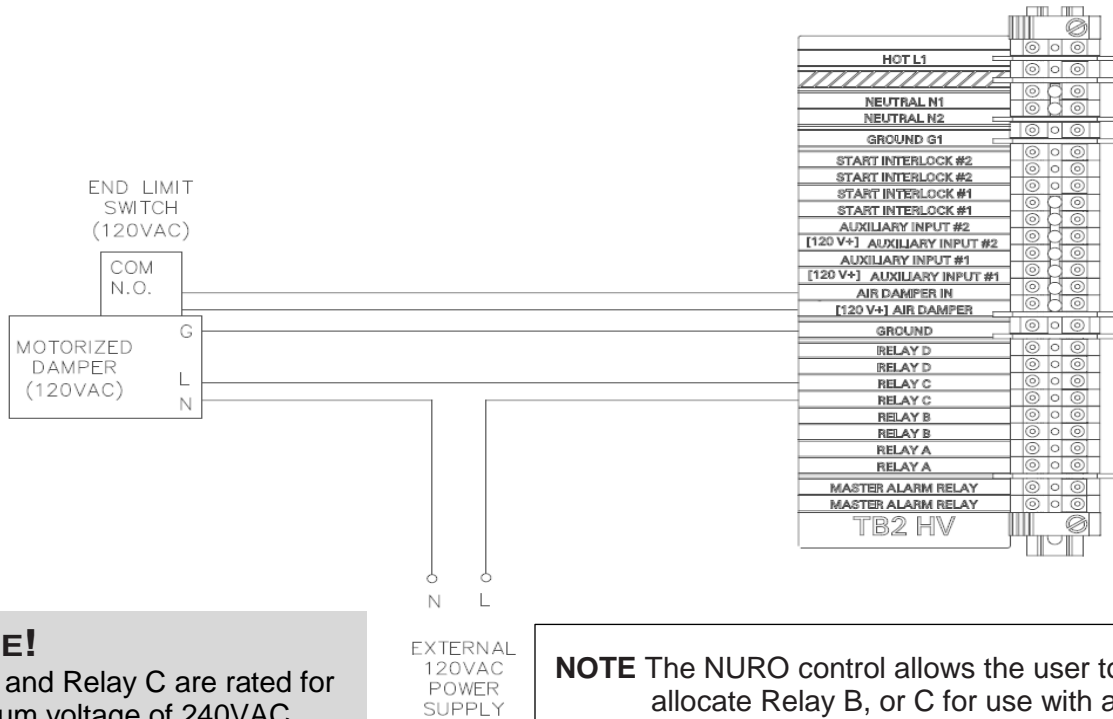

## NOTICE!

Relay B, and Relay C are rated for a maximum voltage of 240VAC and a maximum current capacity of ½ Amp. Connecting a motorized damper which exceeds the voltage or current capacity of the relay could cause permanent damage to the relay.

**NOTE** The NURO control allows the user to allocate Relay B, or C for use with a motorized combustion air damper. The figure above shows Relay C in use for the motorized combustion air damper. Depending on the user-configuration, Relay B, or Relay C can be selected to operate the combustion air damper.

### 3.6.2 Category IV Installations

If the vent installation is designed for Category IV conditions only (condensing – positive pressure) as it is defined in ANSI Z21.13/CSA 4.9, latest edition, the installations shall be in accordance with NFPA 54/ANSI Z223.1, the *National Fuel Gas Code*, or CAN/CSA-B149.1, the *Natural Gas and Propane Installation Code*, or applicable provisions of the local building codes.

#### **WARNING**

**Do not use a barometric damper** if operating with a positive stack pressure (Category IV). Harmful flue gases may leak into the room which can cause serious injury or death.

### 3.6.3 Sealed Combustion/Direct Vent Systems

PK appliances are also certified for operation with a sealed combustion air and pressurized venting systems. Such a system employs a sealed combustion air intake duct leading from outdoors and a sealed exhaust vent terminating outdoors. Air flow through the system is maintained by the combustion air fan. Allowable configurations of vent and air intake terminations are illustrated.

The exhaust vent pressure must not exceed 1.0" W.C. The inlet air duct friction loss must not exceed 0.5" W.C.

If the air inlet and the exhaust vent terminate on the same wall of the building they must utilize the same type of termination fitting.

#### **NOTE**

The above venting criteria equates to properly installed exhaust venting systems consisting of Polypropylene or other approved venting materials in the total amount of two hundred fifty (250) total **equivalent feet** of 6" duct. The resistances of all exhaust vent fittings and installed piping must be considered in the total calculation.

On DIRECT VENT / SEALED COMBUSTION Systems, two hundred fifty (250) **equivalent feet** of venting for exhaust piping shall also apply equally to combustion air inlet piping. All resistances, calculations and fittings apply similarly to combustion air piping.

All venting installations are dependent upon, but not limited to: proper design and installation criteria, building pressure considerations, weather / atmospheric conditions, and relative humidity.

Under no circumstances shall the venting criteria be deemed the sole factor of failure in the event of an excessive back pressure venting fault. A situation of correctly installed venting will not preclude the venting pressure limitation required for proper operation.

#### **Vent Pipe Fittings Equivalent Lengths**

<b>Vent Pipe</b>	<b>Polypropylene 6" Vent</b>	<b>Stainless Steel 6" Vent</b>
90° Elbow	22 feet	20 feet
90° Long Radius Elbow	14 feet	12 feet
45° Elbow	14 feet	12 feet

## HiDRA Through the Wall Venting

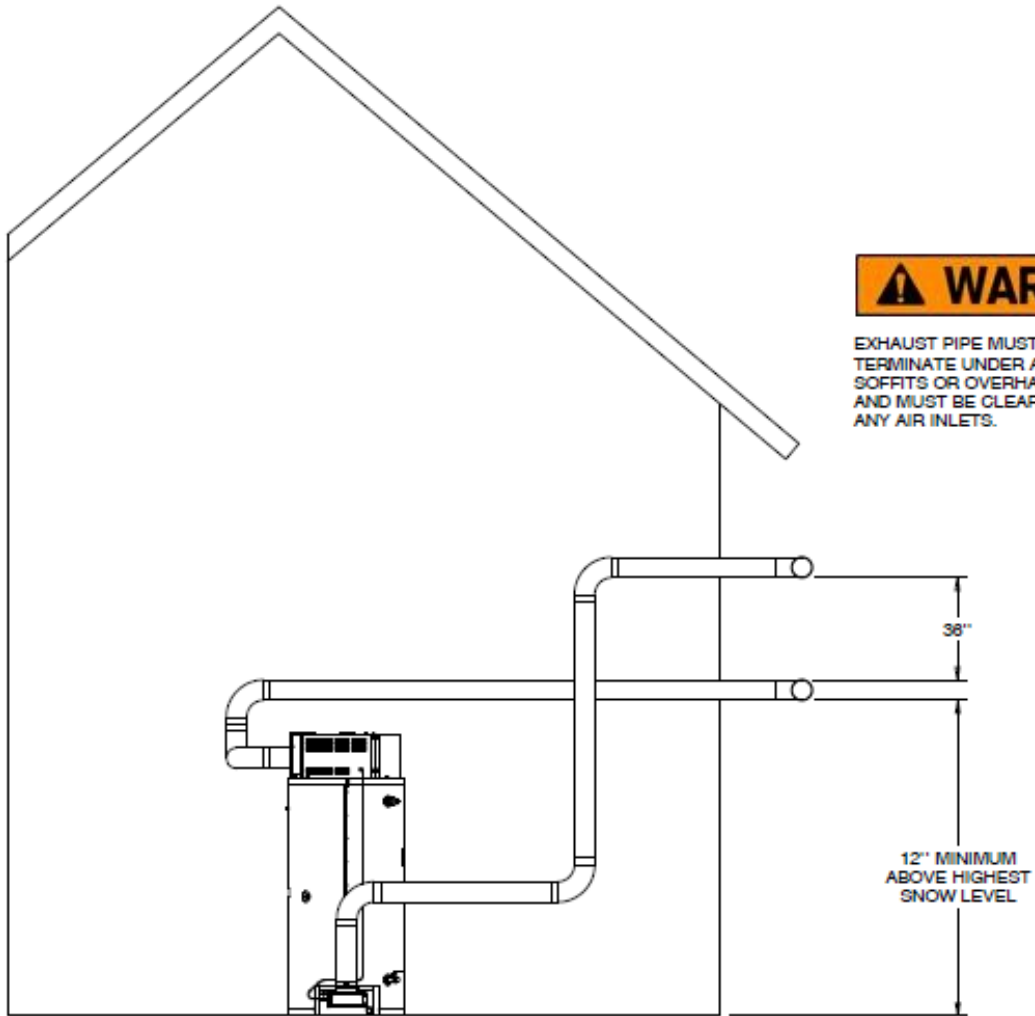

## HiDRA Through the Roof Venting

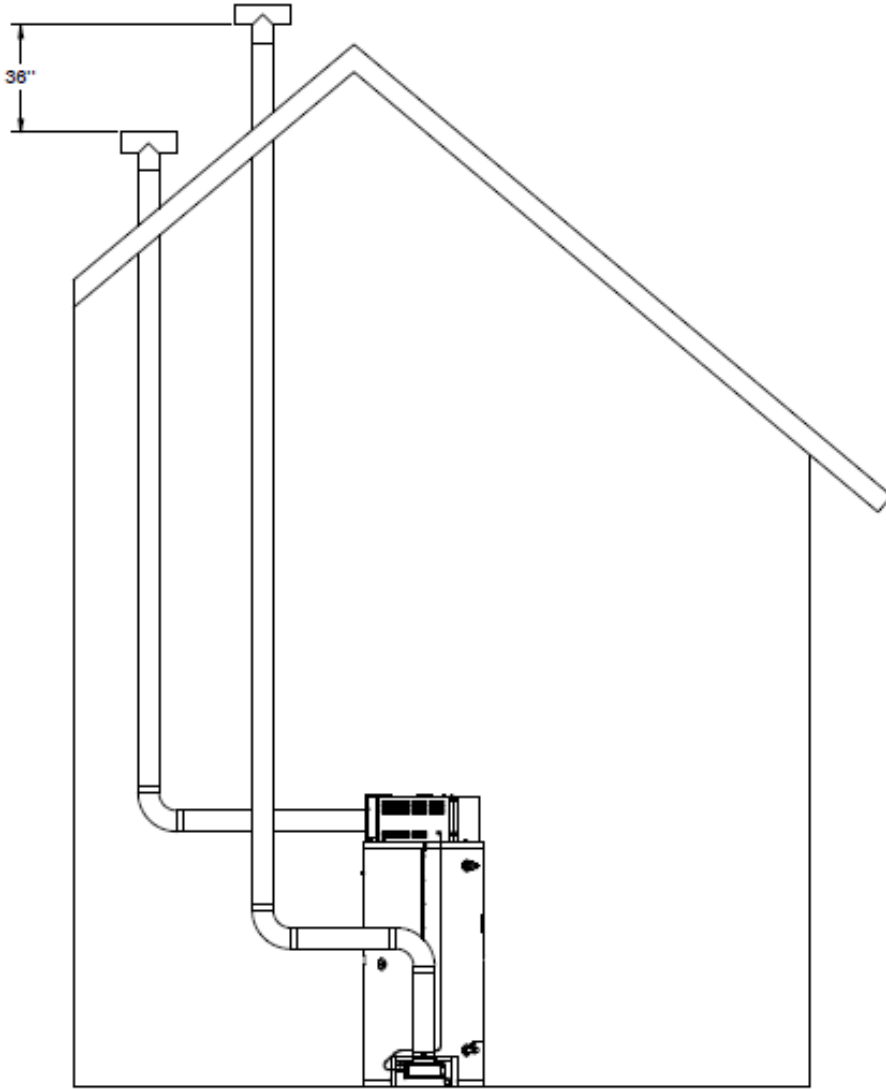

PRELIMINARY

### Combining Vents with a Draft Inducer

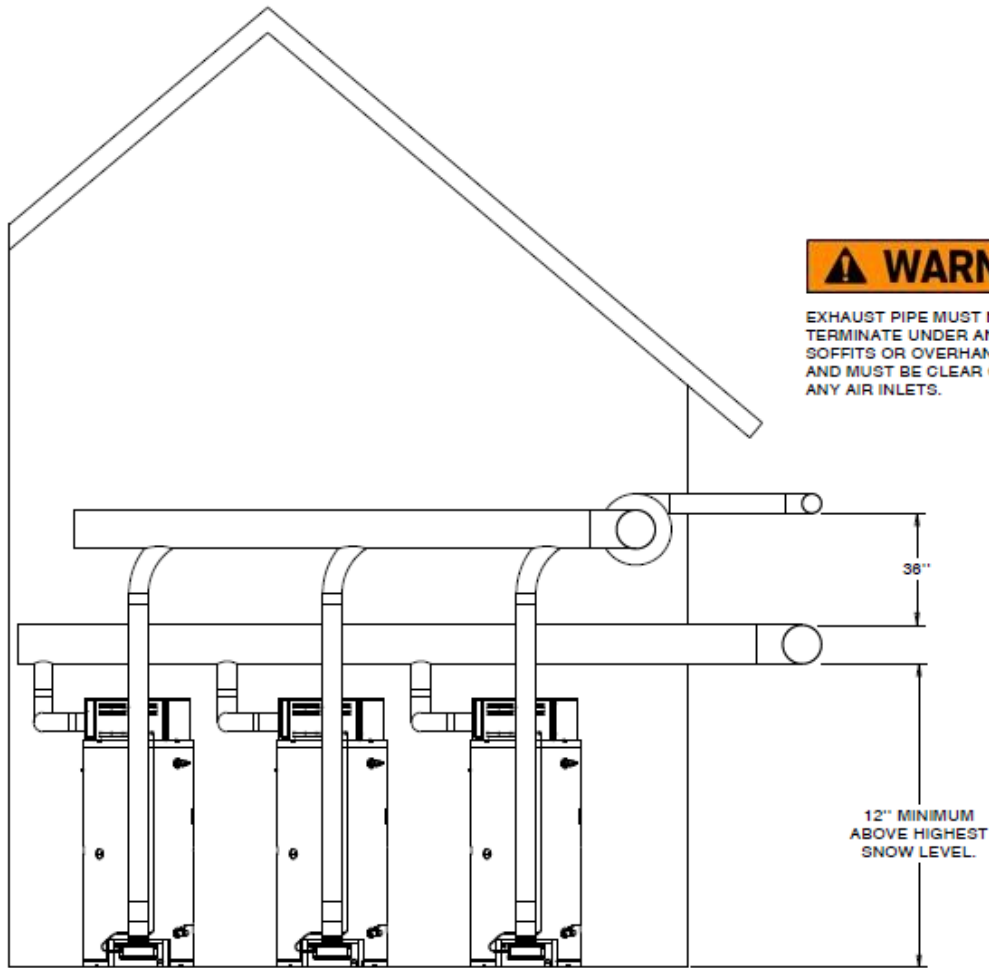

**NOTE:** For **Category II** installations, ensure the flue venting system is designed to maintain a slightly negative exhaust pressure between **-0.01" W.C. and -0.05" W.C.**

**NOTE:** For **Category IV** installations, ensure the flue venting system is designed to maintain a slightly positive exhaust pressure which **MUST BE** in the following ranges:

- **+0.01" W.C. and +0.5" W.C. (Direct Vent / Sealed Combustion)**
- **+0.01" W.C. and +1.0" W.C. (Exhaust Only)**

### 3.6.4 Flue Connection

#### **WARNING**

The appliance vent should not be connected into any portion of another mechanical draft system without consulting the vent manufacturer. The appliance shall not be connected to any part of a vent system serving a Category I or II appliance, nor shall a Category I or II appliance be connected to any part of vent system serving this appliance. Improper interconnection of venting systems may cause leakage of flue gases into occupied spaces. **This can cause serious injury or death.**

The connection from the appliance to the vent should be as direct as possible and the upward slope of any horizontal breaching should be at least 1/4 inch per linear foot. The condensation from the vent is designed to drain back toward the appliance and exit through the appliances condensate trap. The termination fitting can be either horizontal or vertical. Contact vent manufacturer for concentric vent terminations.

#### **NOTICE!**

The condensate formed from natural gas flue gases is acidic. The condensate shall be drained in accordance with local code requirements. A condensate neutralizer may be required by local code.

### 3.6.5 Venting for Multiple Appliances

1. Combined HiDRA Category IV gas vent systems must incorporate a variable speed, modulating, mechanical draft inducer capable of maintaining the appropriate negative draft at the end of the common flue, to assure that all water heaters in the combined vent system operate with a negative draft. All vent systems shall be approved by a certified engineered venting manufacturer.
2. Combining the exhaust vents of multiple HiDRA condensing water heaters into a common, unpowered or "gravity" vent is never recommended (i.e. venting as Category II). HiDRA water heaters are too efficient and the flue products are too cold to generate the natural buoyancy required for such combined vent systems to function reliably and safely.
3. The common mechanical draft vent system must be interlocked, so the water heaters will not begin operation until the common mechanical draft vent system negative pressure is proved to be within the range approved by a certified engineered venting manufacturer.

When combining the exhausts of multiple HiDRA water heaters, do not use individual remote ducts to provide outdoor combustion air.

4. When exhaust vents are combined, it is necessary to install an air inlet damper on each appliance and either
  - a. Draw all combustion air for each heater from the mechanical room in which they are installed or,
  - b. Use a common air supply system that is designed and installed by a qualified professional firm and that meets all the requirements of a certified engineered venting manufacturer.

#### **WARNING**

Do not connect multiple water heaters vents into a single unpowered or fixed speed powered vent. This could cause unsafe operation and the potential for poisonous carbon monoxide to enter occupied areas. Such improper installation can cause property damage, exposure to hazardous materials, personal injury or death.

### 3.6.6 Stainless Steel Venting

The following materials are used by venting manufacturers to produce listed venting systems.



- AL29-4C Stainless Steel Vent Systems listed and labeled to UL1738 *Venting Systems for Gas-Burning Appliances, Categories II, III, and IV*
- 316L Stainless Steel where certified and warranted by the vent manufacturer for venting of Category II, III or IV appliances

These prefabricated venting systems must be installed according to the manufacturer's installation instructions. Special care should be taken to ensure that any and all integral gasketing is properly assembled and creates a gas and water tight seal. Systems that require silicone caulking for gasketing should only be installed with silicone caulk that is recommended by the vent manufacturer, or if none is recommended, only high temperature, waterproof, silicone caulk should be used. Support of venting system must be according to the manufacturer's instructions. The appliance collar shall not be used to support the weight of the vent.

PRELIMINARY DOCUMENT - SUBJECT TO CHANGE

### 3.6.7 CPVC Vent System Installation

Install CPVC vent systems in accordance with this manual and the SMACNA *Thermoplastic Duct Construction Manual*. Install manufactured vent systems in accordance with the manufacturer's listing and instructions. A customer supplied adapter is required to be installed between the appliance and the CPVC venting.

**Table of Stainless Steel Adapter for CPVC Part Numbers**

Water Heater Size	Stack Diameter	Stack Length	Stainless Adapters for CPVC Part Number
HC800	6"	12"	26-8100-0072
HC1000			

See the table above for a list of available adapters for each size HiDRA appliance. Installer should use Adapters listed in the table or an equivalent adapter. When venting this appliance using CPVC vent material, the following operating and installation conditions must be met:

#### Operating Parameters:

- Maximum Water Temperature Set Point 180°F
- Flue Gas Limit 220°F

#### Installation Parameters:

- Cement and primer must conform to ASTM F493
- Three feet of venting closest to the appliance must not be enclosed
- The vent shall not be insulated

**CPVC Support Spacing (Feet)**

Vent Size	Sch 40	Sch 80
4	4	4-1/2
6	4-1/2	5
8	5	5-1/2
10	5-1/2	6
12	6	6-1/2

#### InnoFlue® Single Wall Commercial Venting

Product	Vendor Part #	Diameter
Appliance Adapter	ISSA0606	6"
Elbow	ISEL0687	6"
Termination Tee	ISTT0620	6"
Bird Screen	IASPP06	
Vent Length	ISVL061, ISVL062, ISVL063, ISVL066, ISVL0610	Different overall lengths

### 3.6.8 CONDENSATE DRAIN, TRAP & DISPOSAL

All HiDRA water heaters, except those applied as a booster water heater are for operation with normal cold inlet water temperatures of less than or equal to 110°F and produce a significant amount of condensate. The condensate drain is under slightly positive flue pressure, so the provided 3/4" PVC condensate trap must always be used. This trap is sized and designed to fill with the proper amount of condensate to create a liquid barrier to prevent flue gases escaping through the condensate drain into the installed space.

**WARNING: The trap included with this unit must be installed and maintained as described in these instructions and must be included as part of the condensate piping system. This trap is required to keep potentially hazardous products of combustion from continually entering the installed space where the condensate piping terminates. Failure to properly install this trap can cause, personal injury, exposure to hazardous materials or death.**

1. The condensate drain is located at the bottom rear of the water heater near the flue outlet. Connect the condensate trap assembly to the PVC fitting on the condensate drain pipe. Additional PVC fittings and pipe can be added to the condensate drain connection to relocate the condensate trap assembly as long as all added parts are at the same elevation. After attachment, the trap must be rotated so the offset in the pipe aims down toward the floor. Do not rotate the offset toward the ceiling. Do not use tools to tighten the PVC union. Hand-tighten the PVC union to seat the internal gasket.
2. Do not combine condensate drains from multiple condensing appliances into a single drain line. Route each drain line into a drain suitable for condensate and make certain the end of the drain line is not submerged or otherwise blocked.
3. All condensate plumbing must be protected from freezing. Do not locate the condensate piping such that an ice dam of frozen condensate can block condensate from leaving the outlet.
4. The condensate is only slightly acidic (3-5 PH), however, local codes may require it to be neutralized prior to entering the drainage system. An optional, field installed, Condensate Neutralization System is available from the factory.
5. Connect a condensate drain line or Condensate Neutralization System to the barbed hose connection, sized for 1 heavy wall Vinyl tubing rated for 170°F or higher located at the end of the condensate trap. All piping from the condensate trap to the suitable drain must remain below the highest point (top of the condensate outlet pipe) on the properly attached condensate trap.

### 3.7 Piping

#### 3.7.1 Gas Piping Overview

Before making the gas hook-up, make sure the appliance is being supplied with the type of fuel shown on the appliance nameplate.

**Note**

This water heater is equipped for natural gas.  
Ce chauffe-eau est équipé pour fonctionner au gaz naturel.

This heater is equipped with orifices sized for operation with natural gas.  
Ce chauffe-eau est muni d'injecteurs dimensionnés pour une alimentation en gaz naturel.

The appliance shall be installed such that the gas ignition system components are protected from water (dripping, spraying, rain, etc.) during appliance operation and service (circulator replacement, control adjustment, etc.)

The appliance is factory fire-tested and adjusted for proper combustion. The gas train components are certified to handle a maximum inlet pressure of 14" W.C. (1/2 psig). Typical gas pressure supply for natural gas is 7" W.C. If the available gas pressure exceeds 14" W.C., a suitable additional intermediate gas pressure regulator of the "lock up" type must be provided to reduce the pressure to less than 14" W.C. Refer to appliance label for minimum inlet gas pressure.

**Simplified Gas Piping**

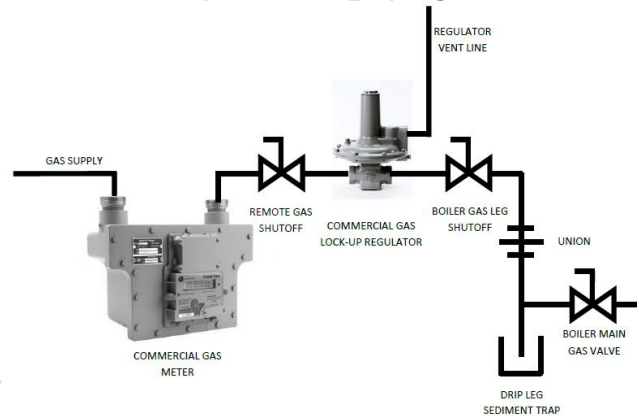

**Minimum Gas Pressure**

	<b>HC800</b>	<b>HC1000</b>
Natural Gas	3.5" W.C	3.5" W.C.

**Note:** When using a vented lock-up gas pressure regulator, the vent piping should be increased by one pipe size for every 10 equivalent feet of length. Never connect vent piping that is small in size than the gas regulator's vent port connection.

Install a sediment trap (drip leg) and a union connection ahead of the primary manual shutoff valve on the appliance. A gas piping schematic is shown above. Gas piping should be installed in accordance with National Fuel Gas Code, ANSI Z223.1, latest edition, and any other local codes which may apply; in Canada see CAN/CSA-B.149.1, latest edition. In the Commonwealth of Massachusetts, the gas cock must be a "T-handle type."

<b>Appliance Size (BTU/Hr)</b>	<b>Natural Gas Requirement (CFH)</b>
800,000	800
1,000,000	1,000

### 3.7.2 Natural Gas Piping

The table below should be used to size the natural gas piping to the appliance. The approximate energy content of natural gas is 1,000 BTU / cu. Ft:

**Pipe Capacity for Natural Gas**

Nominal Iron Pipe Size (Inches)	Internal Diameter (Inches)	Equivalent Pipe Length		Maximum Capacity in Cubic Feet of Natural Gas Per Hour Pressure Drop of 0.5" W.C. Equivalent Length of Pipe (in feet)						
		90° Ell (Feet)	Tee (Feet)	20	40	60	80	100	150	200
1-1/4	1.380	3.45	6.9	974	677	543	472	410	333	287
1-1/2	1.610	4.02	8.04	1500	1020	830	707	636	513	441
2	2.067	5.17	10.3	2820	1950	1560	1330	1180	974	820
2- 1/2	2.469	6.16	12.3	4460	3100	2460	2100	1900	1540	1300
3	3.068	7.67	15.3	7900	5400	4410	3800	3300	2720	2340
4	4.026	10.1	20.2	16100	11100	9000	7690	6870	5640	4720

### 3.7.3 Pressure Testing the Gas Piping

The appliance and all gas piping connections should be pressure-tested and must be checked for leaks before being placed into service. The appliance **must be disconnected** at the manual shut-off valve (located at the end of the supplied gas train) from the gas supply piping during any pressure testing of the system at pressures in excess of 0.0723 psig (2" W.C.). Perform the pressure test with compressed air or inert gas if possible.

Some leak test methods, including the use of soap and water, may cause corrosion of the carbon steel gas pipe fittings. If using soap and water or a similar leak test method, make sure to clean off all moisture from the gas pipe fittings prior to placing the appliance into service.

### 3.7.4 Gas Supply Piping for Installer

The appliance and all gas piping connections should be pressure-tested and must be checked for leaks before being placed into service. The appliance must be **disconnected** at the appliance's manual shut-off valve (located at the end of the supplied gas train) from the gas supply piping system during

any

**NOTE:** Refer to [Appendix D Best Practices For New & Retrofit Systems](#) for best piping practices for both new and retrofit appliance installations.

pressure testing of the system at pressures in excess of 0.0723 psig (2" W.C.). Test with compressed air or inert gas if possible.

During any pressure testing of the gas supply piping system at pressures equal to or less than 0.0723 psig (2" W.C.), the appliance must be isolated from the gas supply piping system by closing the manual shut-off.

Some leak test solutions, including soap and water, may cause corrosion of the carbon steel gas pipe fittings. These leak test solutions should be cleaned off after testing is complete.

### 3.7.5 Appliance Connections

All water connections should be in compliance with national, state and local code requirements.

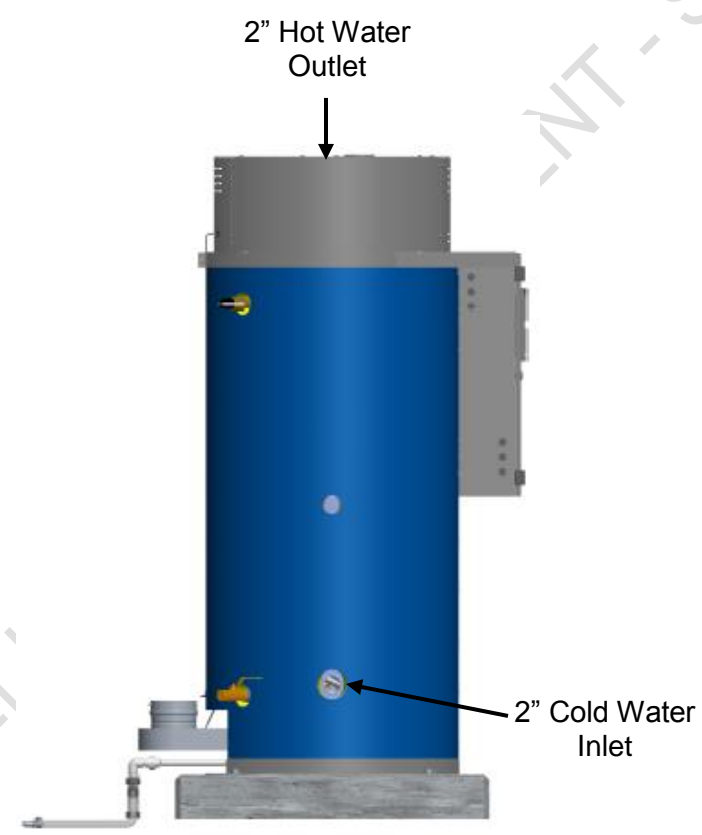
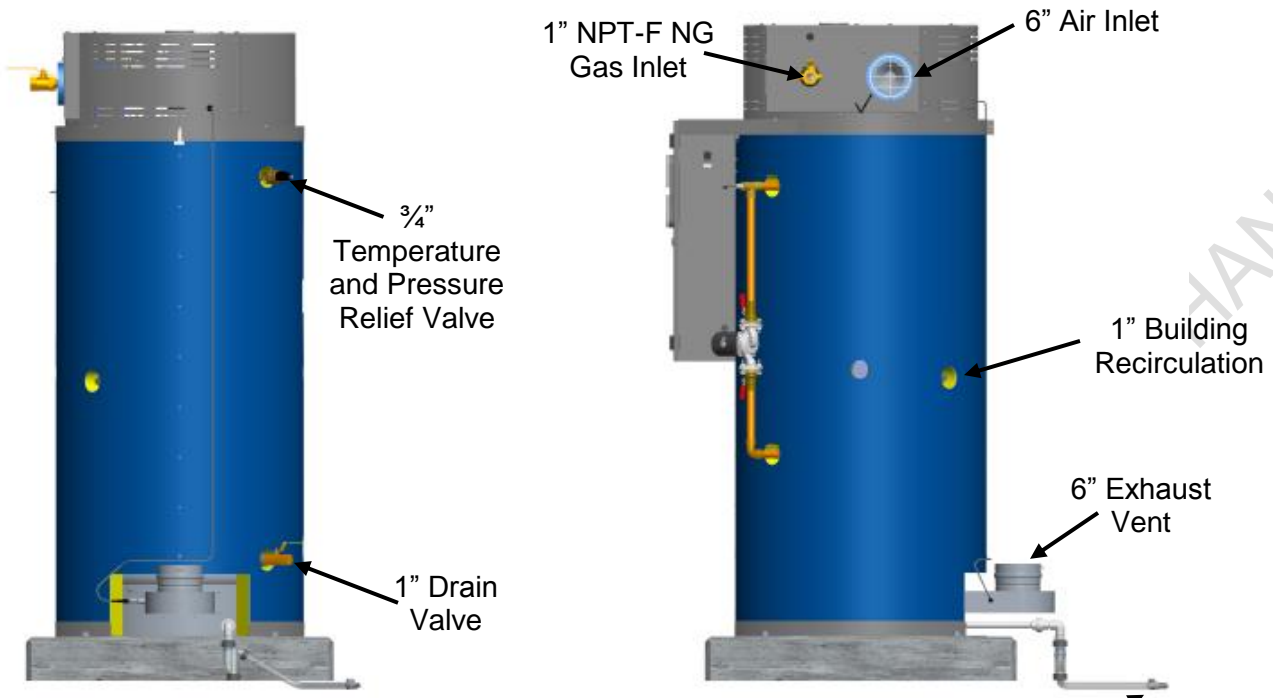

**NOTICE!**  
 Condensate Trap must be piped to condensate neutralization tank & floor drain in accordance with all national, state and local codes. Heat trace may be required to prevent freezing in un-insulated spaces.

### 3.8 Water Quality

The P-K HiDRA appliance's heat exchanger is made of stainless steel. The heat exchanger requires proper water conditions to remain efficient and function properly. For information, please refer to



### 3.9 Pre-Start Checklist

#### NOTICE!

Ensure all air is purged from the appliance's heat exchanger prior to any startup.

#### WARNING

**Never attempt to operate an appliance that has failed to pass all the safety checks described below. Operating an appliance that has failed a safety check could result in injury. Bypassing safety mechanisms will result in unsafe appliance operation which could result in injury or death.**

#### WARNING

**After checking controls by manual adjustment, make sure they are always reset to their proper settings.**

Before attempting to start the appliance, make sure the following items have been completed.

- Inspect the gas train, blower, ignition electrode and appliance in general to be sure there was no damage during shipment or installation.
- Flue gas from the appliance is properly vented.
- Gas connection has been made, pressure tested for leakage and the line purged of air. Make sure all required vents have been installed.
- Water connections are complete and the appliance and system have been filled and purged of air.
- The appliance is connected to the correct electrical power source listed on the nameplate, a disconnect having adequate overload protection is required.
- Combustion air openings are not obstructed in any way and have adequate capacity.
- The appliance is placed the proper distance from any combustible walls.
- Relief valves have been piped to an acceptable drain at a safe point of discharge.
- Condensate piping is properly connected.
- Verify system water quality is within specifications.

## **CAUTION**

The user should become thoroughly familiar with the operation of the appliance and controls before attempting to make any adjustments.

## **CAUTION**

Changing parameters requires an understanding of the parameters and the functionality of the appliance.

The appliance may not function properly if parameters are changed from the factory values.

## **NOTICE!**

If the expected error code(s) do not appear, call for qualified service personnel.

### **3.10 Safety Checks**

The following checks of safety systems must be made before putting the appliance into normal operation. Before firing the appliance refer to [4 Operations](#) section for information on the use of the controls, lighting, and shut-down procedures.

#### **3.10.1 Ignition Safety System Test**

Test the ignition system safety shutdown as follows:

1. Cycle the appliance on by generating a heat request. (The method for this will depend on your appliance configuration.)
2. During the pre-purge cycle (before ignition), smoothly close the downstream manual isolation valve (inside the appliance cabinet) to reduce the gas flow.
3. Closing the manual isolation valve will prevent a successful ignition, and the NURO<sup>®</sup> will display either:
  - 109: **“Ignition Failed”**
  - 110: **“Ignition Failure Occurred”**

These alarms indicate an ignition failure and the lockout will remain until the control is reset. After completing this test, turn the appliance off, open the downstream manual isolation valve, then turn the appliance back on.

#### **3.10.2 Manual Reset High Temperature Limit Test**

The appliance is furnished with a manual reset high temperature limit which features a probe installed near the appliance’s outlet in order to measure the outgoing supply water temperature. This probe is connected to the manual reset high temperature limit by a thin, metal capillary tube. The manual reset high temperature limit is located inside the appliance’s front panel, toward the top of the control panel.

Test the manual reset high temperature limit control as follows:

1. Cycle the appliance on by generating a heat request.
2. Allow the appliance to proceed through ignition until main flame is established.
3. Using a flathead screwdriver, turn down the setting on the manual reset high temperature limit to its lowest value. Turning the screwdriver counter-clockwise decreases the temperature setting.
4. When the outgoing supply water temperature exceeds the setting on the manual reset high temperature limit, the main burner will shut off.

The NURO touchscreen will display 10009: **“High Temperature Limit”**. Return the system to normal operation by readjusting the setting on the manual reset high temperature limit to its default setting, press the reset button on the manual reset high temperature limit, and finally touch any prompts from the NURO control.

#### **3.10.3 Gas Pressure Switch Tests**

##### **Low Gas Pressure Switch**

The appliance is furnished with a low gas pressure switch, installed near the appliance’s main gas shutoff/control valve. The operation of this switch must be checked as follows:

1. Close the main gas cock (external to the appliance).
2. Cycle the appliance on by generating a heat request.
3. Allow the appliance to proceed through pre-purge and attempt ignition.

When the main gas shutoff/control valve opens to attempt ignition, the low gas pressure switch will trip, causing the NURO touchscreen to display 10012: **“Low Gas Limit”**. Even after re-opening the main

gas cock, 10012: “**Low Gas Limit**” will remain on the NURO display until the appliance is manually reset by pressing “Reset Control”.

**NOTE**

Make sure to re-open the main gas cock (external to the appliance) after a successful test.

**High Gas Pressure Switch**

The appliance is furnished with a high gas pressure switch, installed near the appliance’s main gas shutoff/control valve. The operation of this switch must be checked as follows:

1. Before starting the appliance, close the downstream gas cock located inside the appliance’s enclosure.
2. Cycle the appliance on by generating a heat request.
3. Allow the appliance to proceed through pre-purge and attempt ignition.

When the main gas shutoff/control valve opens to attempt ignition, the high gas pressure switch will trip, causing the NURO touchscreen to display 10011: “**High Gas Limit**”. Even after re-opening the downstream gas cock inside the appliance, 10011: “**High Gas Limit**” will remain on the NURO display until the appliance is manually reset by pressing “Reset Control”.

**NOTE**

Make sure to re-open the downstream gas cock (inside the appliance) after a successful test.

**3.10.4 Low Water Cut-out Test**

The appliance is equipped with a probe-type low water cut-out. The probe is typically installed near the appliance’s outlet in order to detect the presence of water at the highest possible location in the appliance.

In order to test the low water cut-out, press and hold the “TEST” button for at least 5 seconds. A manual lockout reset error displaying 10010: “**Low Water Limit**” on the NURO touch screen should occur.

**Optional Test Method:** First turn the appliance off, and then turn off the appliance’s circulating pump. Isolate the appliance from the system. Drain the water level below the low water cut-off probe. Turn the appliance back on. It should not operate, and a manual lockout reset error displaying 10010: “**Low Water Limit**” on the NURO touchscreen should occur.

Return the system to normal operation by refilling with water, restarting the appliance’s circulating pump, and then turning the appliance back on.

## 4 Operations

### **⚠ WARNING**

Do not use this appliance if any part has been under water. Immediately call a qualified service technician to inspect the appliance and to replace any part of the control system and any gas control which has been under water. Failure to do so could result in electrocution, injury, or death.

N'utilisez pas cet appareil s'il a été plongé dans l'eau, même partiellement. Faites inspecter l'appareil par un technicien qualifié et remplacez toute partie du système de contrôle et toute commande qui ont été plongés dans l'eau. Ne pas le faire pourrait entraîner une électrocution, des blessures ou la mort.

### **⚠ WARNING**

If overheating occurs or the gas supply fails to shut off, do not turn off or disconnect the electrical supply to the pump. Instead, shut off the gas supply at a location external to the appliance.

### **NOTICE!**

The On/Off switch only interrupts power to the NURO® control. In order to fully remove power to the entire appliance, use the external disconnect.

### 4.1 NURO® Control Panel

Once the appliance has been installed in compliance with this manual, it is necessary to access the power (on/off) switch located in the upper right hand corner of the NURO control panel as shown below:

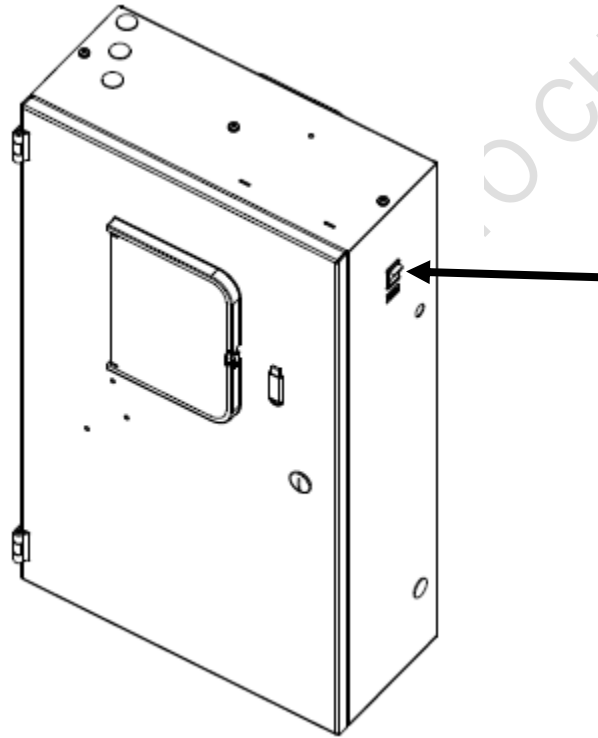

#### 4.1.1 NURO Touch Screen Interface

Once the appliance is switched to the "ON" position, the P-K HiDRA appliance can be programmed and operated with the NURO touch screen interface located on the front panel as shown above. A clear plastic cover protects the touch screen which can be opened by pinching the clasp and swinging open to the left.

#### 4.1.2 Factory Tests

Safe lighting and other performance criteria were met with the gas manifold and control assembly provided on this appliance when the appliance underwent factory tests specified in ANSI Z21.10.3/CSA 4.3, latest edition. (See "Factory Firetest" label on the rear surface of the appliance).

## 4.2 Normal Lighting and Shut-down Procedures

### 4.2.1 Normal Lighting Procedures

1. Make sure the system is filled with water. Turn on the electrical supply and open the gas supply valves to the appliance.
2. Turn the on/off switch to the “On” position. If an error is indicated, refer to the NURO Advanced User’s Guide to troubleshoot the problem and take necessary corrective action before proceeding.
3. Set the desired high temperature limit and operating temperature. The NURO controller will now begin the automatic firing sequence.

### 4.2.2 Normal Shut Down Procedures

1. Allow the appliance to turn off on its own once the temperature satisfies, or remove the call for hot water to the appliance.
2. Once the appliance completes a successful “Post-Purge”, it will return to “Standby”.
3. Once in standby, turn the on/off switch to the “Off” position.
4. Close all manual gas valves to right.
5. Turn off the electrical disconnect to the appliance.

## 4.3 Emergency Shut-Off

In case of emergency, immediately shut off the gas supply at the valve on the top of the appliance. See the image to the right for the locations of the Natural Gas valve (in figure).

## 4.4 Fuel/Air Adjustments

### 4.4.1 Inlet Gas Port

#### **NOTICE!**

Adjustments shall only be performed by service representatives specifically trained and certified to perform maintenance on the Harsco Industrial Patterson-Kelley HiDRA appliance. Verify proper operation after servicing.

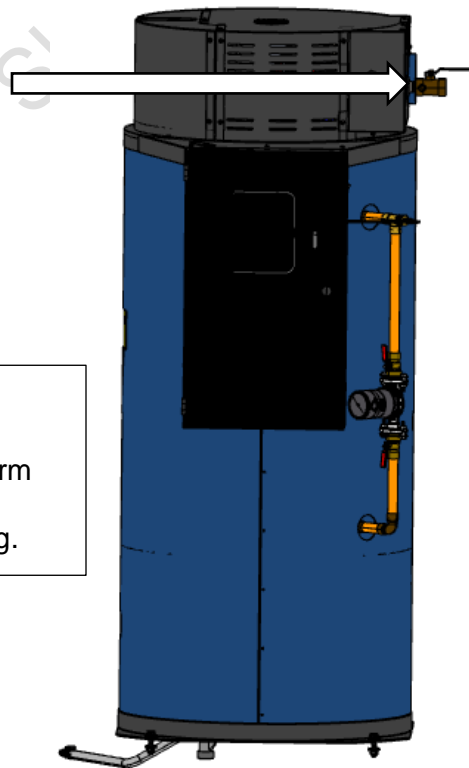

See rating plate for the minimum and maximum inlet gas pressure of the appliance. The supply pressure during main burner operation must be greater than the minimum indicated on the rating plate.

Nominal gas supply pressure is 7" W.C. for natural gas. The gas pressure must not exceed 14" W.C. which is the maximum allowable pressure on the gas train components. Each appliance is furnished with a manual shut-off valve which has an integrated test port. This port is located on the upstream side of the valve body for measuring supply pressure.

The air flow is pre-set at the factory prior to shipment. Gas flow is dependent primarily on fan speed not upstream gas pressure. The air/gas ratio may have to be adjusted to obtain proper combustion readings for specific local conditions. A combustion analyzer must be used. The probe must be placed in the exhaust vent immediately after the appliance. Combustion should be adjusted in accordance with Table of Combustion Exhaust Settings.

**NOTICE!**

For high altitude adjustments (greater than 2,000 feet above sea level), see [Appendix B – Appliance Altitude Derate Schedule](#) at the end of this manual.

## 4.4.2 Combustion Setup and Adjustment

### Appliance Test Mode for High and Low Fire

To adjust/tune combustion, use the NURO's "Manual Control Firing Rate" mode. To access, touch the "Info" button in the lower left corner of the screen, and then touch "Service" in the lower left. Next, touch "Press to Activate Manual Control" which will open the "Manual Control Firing Rate" mode. This test mode should be used when adjusting or tuning the gas safety shut off/control valve on the appliance.

Once the appliance cycles on and is running in "Manual Control Firing Rate", use the UP and DOWN arrow keys or the slider to force the appliance to operate at low fire or high fire (or anywhere in-between).

### **WARNING**

In Manual Control Firing Rate mode, the outlet water may get much higher than setpoint. Ensure appliance is isolated from system to prevent scalding.

### Recommended Combustion Settings for P-K HiDRA Appliances

	Fuel	Nominal Inlet Gas Pressure*	High Fire Setting		Low Fire Setting	
			% O <sub>2</sub>	% CO <sub>2</sub>	% O <sub>2</sub>	% CO <sub>2</sub>
HC800	Natural Gas	7" W.C	4.0 – 4.5	9.5 – 9.8	4.5 – 5.0	9.0 – 9.5
HC1000	Natural Gas	7" W.C	4.0 – 4.5	9.5 – 9.8	4.5 – 5.0	9.0 – 9.5



### 4.4.3 Adjusting High Fire (DUNGS Valve)

**NOTE: ALWAYS** adjust high fire combustion first!

Start the appliance and observe proper operating parameters for the system. Access the “Manual Control Firing Rate”, as described above, and increase the firing rate to 100%. Check combustion readings using the combustion analyzer. If the combustion readings are not in accordance with [Section 4.4.2](#), adjust as follows:

**Required Tools:** Slotted screw driver/ 2mm hex wrench, Combustion analyzer and water tube manometer.

1. Using a slotted screw driver, set the maximum restrictor (high fire screw) on the outlet/shutter flange of the combination gas safety shut off / control valve by turning clockwise or counterclockwise to achieve the desired CO<sub>2</sub> or O<sub>2</sub> level. To increase the O<sub>2</sub> level, adjust towards the “-“ symbol to decrease gas flow. To decrease the O<sub>2</sub> level, adjust towards the “+” symbol to increase gas flow.
2. There will be a slight time delay between the adjustment and the response of the CO<sub>2</sub>/O<sub>2</sub> measuring instrument.

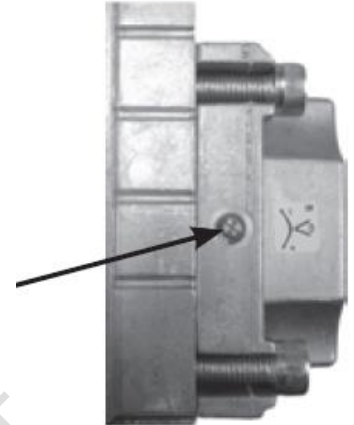

### 4.4.4 Adjusting Low Fire (DUNGS Valve)

Start the appliance and observe proper operating parameters for the system. Access the “Manual Control Firing Rate”, as described above, and decrease the firing rate to 1%. Once the appliance has reached low fire operation, check combustion readings using the combustion analyzer. If the combustion readings are not in accordance with [Section 4.4.2](#), adjust as follows:

1. Using a 2 mm hex wrench, adjust the pressure regulator offset adjustment (pictured above) to achieve the desired CO<sub>2</sub> /O<sub>2</sub> level. To increase the O<sub>2</sub> level, adjust towards the “-“ symbol to decrease gas flow. To decrease the O<sub>2</sub> level, adjust towards the “+” symbol to increase gas flow.
2. Adjustments to the offset pressure regulator should not exceed ¼ turn at a time before allowing the readings to respond and stabilize.

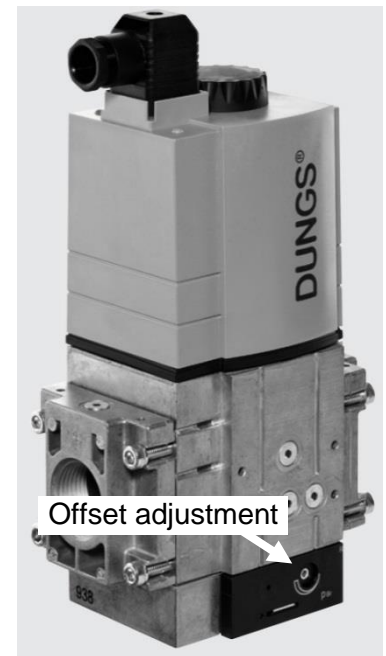

Following all gas valve adjustments, check for proper light-off and verify correct fuel/air mix and combustion quality throughout the entire firing range (from low fire to high fire).

**Required Tools:** TORX® T40 or 5 mm hex wrench, 3 mm or 7/64 in hex wrench, Combustion analyzer.

#### 4.4.5 Adjusting High Fire (Honeywell Valve)

Start the appliance and observe proper operating parameters for the system. Set appliance to the "Manual Control Firing Rate", as described above, and increase the firing rate to 100%. Check combustion readings using the combustion analyzer. If combustion readings are not in accordance with Table of Combustion Exhaust Settings, adjust as follows:

1. Remove the flat, round, blue plastic cap from the gas valve.
2. Using a 3mm (7/64") hex wrench, adjust the high fire screw, see the figure right.
3. On each of the gas control valves turn clockwise or counterclockwise to achieve the desired CO<sub>2</sub> or O<sub>2</sub> level; see table for Combustion Exhaust Settings for correct settings.  
There will be a time delay between the adjustment and the response of the CO<sub>2</sub>/O<sub>2</sub> combustion analyzer.
4. Adjust the settings in small increments. When desired adjustments are complete, reinstall the blue plastic cap on the gas valve.

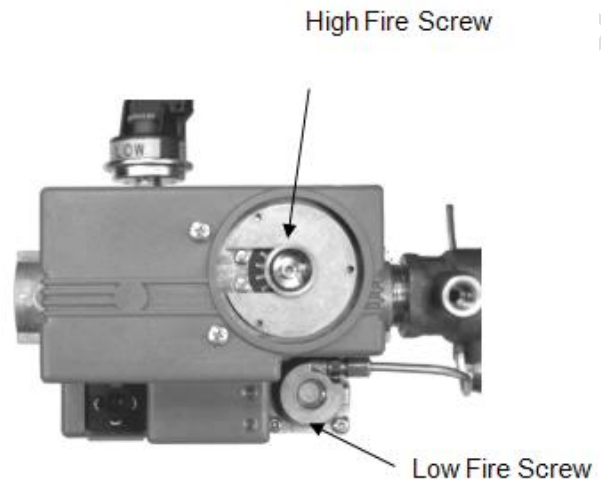

#### NOTICE!

There will be a slight time delay between the adjustment and the response of the CO<sub>2</sub>/O<sub>2</sub> measuring instrument. Adjust the settings in small increments and allow the combustion readings to stabilize before readjusting. When desired adjustments are complete, check and adjust low fire if necessary.

#### 4.4.6 Adjusting Low Fire (Honeywell Valve)

Start the appliance and observe proper operating parameters for the system. Set appliance to the "Manual Control Firing Rate", as described above, and decrease the firing rate to 1%. Once the appliance has reached low fire operation, check combustion readings using the combustion analyzer. If combustion readings are not in accordance with Table of Combustion Exhaust Settings, adjust as follows:

1. Remove the gray cap on the gas regulator using a slotted screwdriver. This will expose the low fire adjustment screw.
2. Using a TORX T40 or a 5 mm hex wrench, adjust the low fire screw on the pressure regulator (see the figure above) to achieve the correct CO<sub>2</sub> /O<sub>2</sub> level.
3. Adjustments to low fire should not exceed ¼ turn at a time before allowing the readings to respond and stabilize. Clockwise rotation increases gas flow. Counterclockwise rotation decreases gas flow.
4. After the low fire adjustment is made, reinstall the slotted cap on the regulator.

#### NOTICE!

The rotation of the Low Fire adjustment screw is opposite to the High Fire adjustment screw.

Following all gas valve adjustments, check for proper light-off and verify correct fuel/air mix and combustion quality throughout the entire firing range (from low fire to high fire).

#### Checking Flame Signal

Press the “Info” button on the NURO touch screen to load the Information Screen and scroll down to view the flame signal measured in Volts. Typical flame signals should read 15V.

PRELIMINARY DOCUMENT - SUBJECT TO CHANGE

## 4.5 Initial NURO Control Setup & Adjustment

This manual covers basic NURO control setup and adjustment.

### 4.5.1 Startup

When the appliance is powered on, the NURO touchscreen will display an initial Startup Screen then the **Local Representative** screen. This shows the name, address and phone number of the local HARSCO Industrial representative.

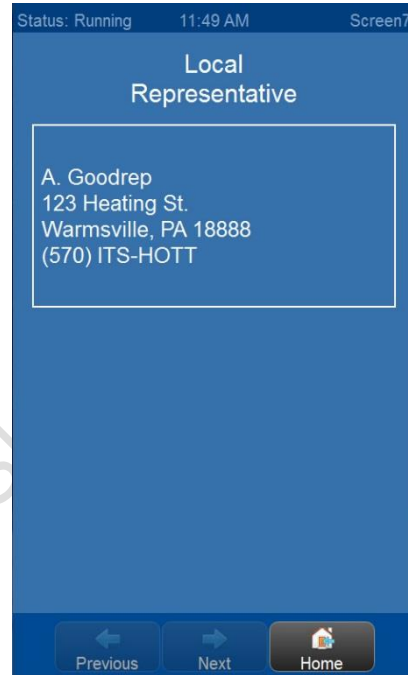

## 4.5.2 Home Screen

After a brief time, the **Local Representative** information screen will timeout displaying the **Home Screen**. The **Home Screen** shows a snapshot of the appliance's current operating conditions:

- Outlet (Supply) Temperature
- Exhaust Temperature
- Firing Rate, etc.

Pressing the “**Info**” button in the lower left corner will load the **Information** screen.

## 4.5.3 Information Screen

The Information Screen contains real-time read-only values such as temperatures, relay states, etc. Scroll through the Information Screen by sliding your finger up or down.

This screen is helpful to determine the operating characteristics of the appliance.

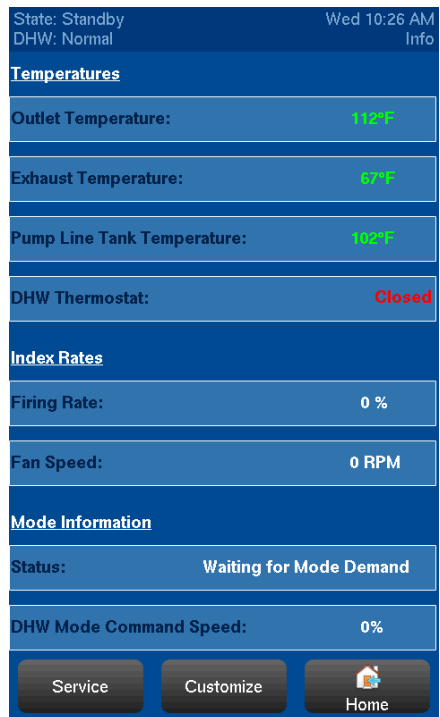
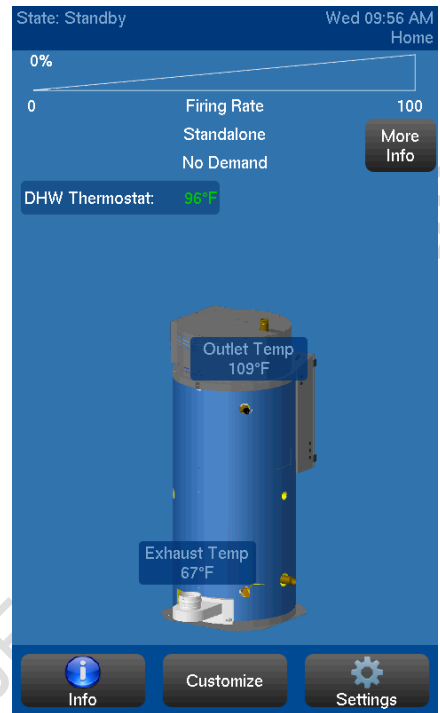

**NOTE:** The relay assignments **must** agree with the wiring to/from the appliance. For example, if Relay B is user-configured to enable/disable the DHW Pump, the control wires to operate the DHW pump must be properly wired to the Relay B terminals in the High Voltage (TB2) terminal block.

## 4.6 Typical Operating Conditions

Model Number	Input Rating (BTU/Hr)	Voltage	Phase	Total Amperage	Gas Flow Rate (CFH)	
					Natural Gas (1000 Btu/ft <sup>3</sup> )	Recovery (Gal/Hr) 40-140°F
HC800	800,000	110-120	Single	Less than 6	800	912
HC1000	1,000,000	110-120	Single	Less than 10	1000	1140

PRELIMINARY DOCUMENT - SUBJECT TO CHANGE

## **⚠ WARNING**

Lockout/tagout procedure must be employed when servicing this unit. Failure to do so could result in electrocution, injury, or death.

## **⚠ WARNING**

Use care when reassembling the main gas line and ensure all connections are tight. Use a leak detector to check for leaks before and after servicing any component of the gas piping. Failure to do so could result in injury or death.

## **⚠ WARNING**

Use care when servicing appliances to prevent the accumulation of gas in or around the combustion chamber. Pockets of accumulated gas are subject to combustion and/or explosion which could result in injury or death.

## **⚠ WARNING**

Determine the cause of any lockout or errors before resetting the appliance. If able to determine cause of lockout, take appropriate corrective action. If unable to determine cause of the problem, call a qualified service technician. Verify proper operation after servicing.

## **⚠ WARNING**

Check daily to be sure that the appliance area is free and clear of any combustible materials, including flammable vapors and liquids.

Combustion Setup and Adjustment combustion settings table. If an adjustment to the combustion is necessary, call a qualified and knowledgeable installer or service agency that has been trained on the Harsco Industrial Patterson-Kelley appliances.

Refer to [4.4.2 Combustion Setup and Adjustment](#).

## 5 Maintenance

This schedule applies when the appliance is in constant use. The section is divided into critical Semi-Annual and Annual Maintenance followed by scheduled routine maintenance.

## **⚠ CAUTION**

Label all wires prior to disconnection when servicing controls. Wiring errors can cause improper and dangerous operation. Verify proper operation after servicing.

Au moment de l'entretien des commandes, étiquetez tous les fil savant de les débrancher. Des erreurs de câblage peuvent entraîner un fonctionnement inadéquat et dangereux. S'assurer que l'appareil fonctionne adéquatement une fois l'entretien terminé.

### 5.1 Preventative Maintenance

#### **NOTICE!**

Proper maintenance schedule and record keeping is critical for optimum performance and to maintain the Harsco Industrial Patterson-Kelley warranty.

#### **NOTE**

The blower motor is permanently lubricated and does not require periodic lubrication.

#### 5.1.1 Daily Preventative Maintenance

Observe operating temperature and general conditions. Make sure that the flow of combustion and intake air to the appliance are not obstructed. Determine the cause of any service codes or lockouts on the display panel. Observe any unusual noises or operating conditions and make the necessary corrections. Notify responsible individuals for required corrective action or repair. As required, flush and clean out tank.

#### 5.1.2 Weekly Preventative Maintenance

Observe the conditions of the main flame.

Correct air adjustment is essential to the efficient operation of this appliance. Ensure that the flow of combustion and ventilation air is not obstructed.

If an adjustment in the combustion appears necessary, the flue gas composition should be checked with a carbon dioxide (CO<sub>2</sub>) or oxygen (O<sub>2</sub>) analyzer and compared to the values stated in the



### 5.1.3 Monthly Preventative Maintenance

1. Press the "Info" button on the NURO touch screen to load the Information Screen and scroll down to view the flame signal measured in Volts. Typical flame signals should read 15V.
2. Test the low water level cut-off. Refer to [3.10.4](#).
3. Test the manual reset high-temp limit. Refer to [3.10.2](#).
4. Test low gas pressure switch. Refer to [3.10.3](#).
5. Test operating temperature controls by reducing or increasing temperature setting as necessary to check burner operation.
6. Check the condensate drain system. Clean and flush as necessary.

This schedule applies when the appliances are in constant use. The section is divided into critical Semi-Annual and Annual Maintenance followed by schedule routine maintenance.

#### NOTICE!

Installation and service must be performed by a qualified installer or service agency that has been trained on the HiDRA appliance.

### 5.1.4 Semi-Annually

In addition to the recommended monthly service:

1. Clean burner of any accumulated dust or lint. Refer to [5 Maintenance](#) and [5.2 Cleaning the Burner & Combustion Chamber](#).
2. Inspect burner for any signs of deterioration or corrosion. Replace immediately if deterioration or corrosion is evident.
3. Inspect and clean the condensate system and check for leaks. If a condensate neutralization kit is present, open the lid and inspect the Magnesium Hydroxide Pellets. If they are absent or have been significantly worn away, replace them with new Magnesium Hydroxide Pellets. Use high-calcium (or pure) Magnesium Hydroxide.

### 5.1.5 Annually

In addition to the recommended monthly and semi-annual service:

1. Inspect and clean the inlet screen of any accumulated dust or lint.
2. Check burner and clean off any soot or foreign material that may have accumulated. Refer to [5 Maintenance](#) and [5.2 Cleaning the Burner & Combustion Chamber](#).
3. Check for corrosion of the burner and its parts. If there is evidence of deterioration or corrosion, replace immediately. Inspect combustion chamber when the burner is removed for inspection. Note any signs of deterioration. Clean as necessary.
4. Inspect and clean heat exchanger. Be sure to inspect condensate collection pan that is the lowest part of the heat exchanger.
5. Replace the ignition electrode, ground rod, and gasket.
6. Inspect and clean the condensate system and check for leaks. If a condensate neutralization kit is present, open the lid and inspect the limestone rocks. If they are absent or have been significantly worn away, replace them with new limestone rocks. Use high-calcium (or pure) limestone or Magnesium Hydroxide pellets.
7. Examine the venting system. Refer to the vent manufacturer's instructions for requirements in addition to those listed below.
  - a. Check all joints and pipe connections for tightness.



- b. Check pipe for corrosion or deterioration. If any piping needs replacing, do so immediately.
  - c. Inspect and clean any screens in the vent terminal.
8. Qualified service personnel should thoroughly inspect the heating system and correct any problems prior to re-starting the appliance.
  9. Perform combustion analysis and readjust as necessary according to the Combustion Setup and Adjustment combustion settings table. Refer to [4.4.2 Combustion Setup and Adjustment](#).
- Note:** It is recommended that a copy of this report is filed for future reference.
10. Perform a leak test of the gas valves in accordance with the manufacturer's instructions.
  11. Perform a test of the relief valves and make sure they properly seat and close as to prevent leaking.

**NOTE**

If a relief valve discharges periodically, this may be due to thermal expansion in a closed water supply system. Contact the water supplier or local plumbing inspector on how to correct this situation.

**NOTE**

This water heater is provided with a combination temperature-pressure relief valve. For safe operation of the water heater, the relief valve must not be removed from its designated point of installation or plugged.

Ce chauffe-eau est équipé d'une soupape de décharge. Pour assurer le fonctionnement sécuritaire du chauffe-eau, ne pas retirer ni obturer cette soupape de décharge.

**⚠ WARNING**

Do not plug the relief valve. Relief valve required for all ASME pressure vessel equipment to ensure maximum pressure is not exceeded.

## 5.2 Cleaning the Burner & Combustion Chamber

Contact Patterson-Kelley for assistance cleaning the burner & combustion chamber.

Harsco Industrial Patterson-Kelley recommends cleaning the burner and combustion chamber once annually:

### Required Replacement Parts

**NOTE**

Spare parts and replacement parts can be ordered from Harsco Industrial Patterson-Kelley by calling toll free **(877) 728-5351**. Reach us by fax at **(570) 476-7247**.

Water Heater	Part	Part Number
HC800 & HC1000	Burner Gasket	26-8200-0027

1. Lockout/Tagout gas supply to the appliance.
2. Lockout/Tagout electrical power to the appliance.
3. Disconnect the condensate neutralization tank piping in order to install a temporary drain hose into the condensate trap/drain. Run the open end of this hose to a nearby floor drain.

4. Remove the wires/cables from the ignition electrode and ground rod.
5. Disconnect the wire plug/lead to the high gas pressure switch (closest to the blower).
6. Disconnect the two wire plugs/leads to the blower.
7. Remove the six 13 MM nuts at the blower inlet.
8. Remove the four 13 MM nuts between the blower outlet and the burner plate.
9. Carefully remove burner and burner gasket by lifting out vertically and clean with pressurized water (approximately 40 psig).

#### NOTE

Do not attempt to wash the burner while installed in the appliance. When cleaning the burner, use a mild detergent such as Simple Green to help loosen built-up debris trapped in the burner mesh.

10. Visually inspect refractory for any cracking.
11. Now that the burner is removed, the burner hole is open which provides access to the combustion chamber.
12. Use a pressurized water hose with control nozzle. Begin by spraying just a few seconds of water into the combustion chamber and then close off the nozzle.
13. Walk around to the rear of the boiler and ensure the wash water is draining into the temporary drain hose off the condensate drain. Adjust the temporary drain hose if needed to help drain the wash water from the appliance.
14. After inspecting the temporary drain hose, continue washing the internal combustion chamber with pressurized water for several minutes. Spray as much of the internal surface area as possible.

#### CAUTION

Be very careful when cleaning to avoid spraying any of the electrical or control components. Water may cause a short circuit and damage circuitry.

15. After several minutes of washing, turn off the hose and allow all the wash water to drain from the appliance.
16. Reconnect the condensate tubing to the condensate neutralization tank.
17. Reinstall a new gasket, and **CAREFULLY** insert the burner into the burner hole.
18. Reinstall the ignition electrode assembly (if previously removed).
19. Reinstall the ground rod assembly (if previously removed).
20. Reinstall the wires/cables to the ignition electrode and ground rod.

#### NOTE

#### WARNING

Crystalline silica may be present in this equipment. Exposure to crystalline silica may pose significant health hazards, including but not limited to eye and respiratory system damage. Personal Protective Equipment must be worn to minimize exposure to hazardous substances. Refer to most current guidelines by the CDC and OSHA for more information, including Personal Protective Equipment recommendations.

## **WARNING**

### **PRECAUTIONS ASSOCIATED WITH HANDLING REFRACTORY LINING MATERIAL**

- This Patterson-Kelley product contains a Combustion Area lined with **REFRACTORY CERAMIC FIBERS (RCFs)** similar to many other devices produced in this industry.
- RCFs have been identified by the **International Agency for Research on Cancer (IARC)** as possibly being carcinogenic to Humans.
- AVOID breathing particles or dust from **RCFs** and avoid contact with Skin or Eyes.
- The **National Institute for Occupational Safety and Health (NIOSH)** recommends the use of a respirator meeting current standards, to avoid inhalation of dust. Also recommended is loose fitting, long sleeved clothing, eye protection and gloves whenever handling **RCFs**. Current **NIOSH** Recommendations are listed on their website at <http://www.cdc.gov/niosh/homepage.html>, which should be viewed before the handling or removal of Refractory Lining Materials on this or any similar device.
- Using a **SPRAY BOTTLE**, saturate with **WATER**; but not dripping, the combustion chamber lining to prevent dust from becoming airborne.
- Place removed **RCFs** into a plastic bag for disposal with normal trash.
- Wash exposed clothing (if not disposable), **TWICE** and **DRY** separately from other laundry.

### **5.3 After Repairs or Maintenance**

Following any major repairs or preventative maintenance, follow the steps below before returning the appliance to service.

1. Follow “[3.9 Pre-Start Checklist](#)” and all safety checks in “[3.10 Safety Checks](#)”.
2. Check the gas pressure, refer to [4.4.1 Inlet Gas Port](#) to ensure proper operation of the appliance.
3. Perform combustion check. Refer to [4.4.2 Combustion Setup and Adjustment](#). Adjust air/gas mixture at high fire & low fire if the O<sub>2</sub>% or CO<sub>2</sub>% are out of range.

#### **NOTE**

Installation and service must be performed by a qualified installer or service agency that has been trained on the Harsco Industrial Patterson-Kelley appliance!

## **CAUTION**

Be very careful when cleaning to avoid spraying any of the electrical or control components. Water may cause a short circuit and damage circuitry.

## ⚠ WARNING

If any “Manual Reset” limit device trips, **DO NOT** reset without determining and correcting the cause. Manual Reset Limits include: Flame safeguard, high or low gas pressure, high temperature limit, stack temperature, low water level. Attempting to operate an appliance without diagnosing the cause of failure can result in unsafe operation, increasing the risk of injury. Never attempt to bypass a safety limit device.

## 5.4 Sequence of Operations

1. When the appliance On/Off switch is turned on, power is provided through over-current protection (fuse and/or circuit breaker) to the appliance control and the combustion blower.
2. When the outlet water temperature drops below “**DHW SETPOINT**” minus “**DHW DIFFERENTIAL ON**”, a heat request is generated.
3. Provided all interlocks are made and the DHW Stat is active, the appliance will attempt to start.
4. The NURO control checks to make sure air pressure switch is open indicating there is no airflow through the appliance. The combustion blower is then driven towards the pre-start fan speed. When the air pressure switch closes, the “**PRE PURGE TIME**” timer is started. Once the “**PRE PURGE TIME**” timer expires, the blower is driven to the ignition speed.
5. A trial for ignition begins and the sequence of events is illustrated graphically on the next page. A valid flame signal must be detected within 4 seconds after the gas valves open (elapsed time 7 seconds).
6. After a successful ignition, the fan is released to modulation.
7. The NURO Control modulates the firing rate between low and high fire to maintain the desired outlet water temperature.
8. The burner will continue firing until the outlet water temperature exceeds “**DHW SETPOINT**” plus “**DHW DIFFERENTIAL OFF**”. At this temperature, the gas valves are closed and the combustion air fan continues to run until the “**POST PURGE TIME**” timer has expired.
9. When the outlet water temperature is reduced by the load on the system, a heat request is generated. The operating sequence will recycle to *Step 3*.

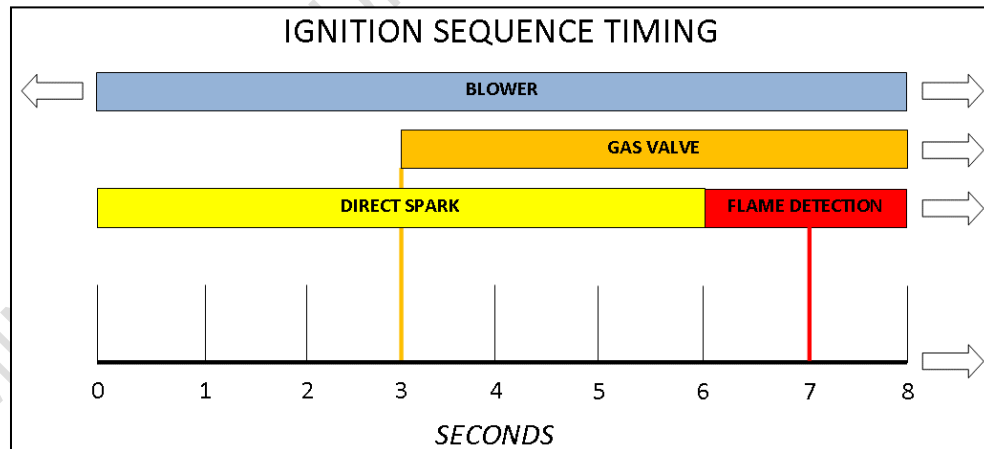

## 5.5 Troubleshooting

The NURO control will display graphical and/or text based error descriptions to announce any problems with the appliance. There are two types of lockouts: manual reset lockouts which require the operator

to physically press the on-screen or device's reset button, and automatic reset lockouts which will self-reset when the error condition clears. For a comprehensive list of errors and potential resolutions, please refer to the NURO Advanced User's Guide.

Should the unit fail to operate, call a qualified service technician to troubleshoot the problem and implement corrective actions.

### 5.5.1 Loss of Power

In the event of a power failure, the NURO touch screen will go dark and the entire appliance will de-

#### **⚠ WARNING**

If any "Manual Reset" limit device trips, **DO NOT** reset without determining and correcting the cause. Manual Reset Limits include: Flame safeguard, high or low gas pressure, high temperature limit, stack temperature, low water level. Attempting to operate an appliance without diagnosing the cause of failure can result in unsafe operation, increasing the risk of injury. Never attempt to bypass a safety limit device.

energize. The signal relays used to command auxiliary devices connected to the appliance (air dampers, pumps, etc.) will also lose power, so these devices will deactivate. When power is restored, the sequence of operation will resume at [Step 3 \(Sequence of Operations\)](#).

If any error/lockout errors were present at the time of the power failure, the NURO control will retain that error/lockout when power is restored.

### 5.5.2 Loss of Water Flow

If the low water cutoff is installed an insufficient water level in the appliance, the NURO control will display 10010: "**Low Water Limit**", close the gas valve, and lock the appliance out. When the water level is corrected and the on-screen reset button is pressed, the appliance will reset and resume the sequence of operation at [Step 3 \(Sequence of Operations\)](#).

### 5.5.3 Low Gas Pressure

The low gas pressure switch opens when there is (or has been) insufficient gas pressure available for proper operation of the appliance. If an external gas-supply shut-off valve is closed for any reason, a low gas condition will result. The NURO control will display 10012: "**Low Gas Limit**", close the gas valve, and lock the appliance out. When proper gas pressure is restored, and the on-screen reset button is pressed, the appliance will reset and resume the sequence of operation at [Step 3 \(Sequence of Operations\)](#).

### 5.5.4 High Gas Pressure

The high gas pressure switch opens when there is (or has been) excessive gas pressure for the proper operation of the appliance. The NURO control will display 10011: "**High Gas Limit**", close the gas valve, and lock the appliance out. When proper gas pressure is restored, and the on-screen reset button is pressed, the appliance will reset and resume the sequence of operation at [Step 3 \(Sequence of Operations\)](#).

### 5.5.5 High Water Temperature

When the appliance's water has exceeded both the operating temperature limit and the manual reset high-temperature limit, the NURO control will display 10009: "**High Temperature Limit**", close the gas valve, and lock the appliance out. When the water temperature falls below the high-limit temperature setting, the appliance will remain locked out until the water high-temperature limit switch is manually reset and the on-screen reset button is pressed. Once reset, the control will resume the sequence of operation at [Step 3 \(Sequence of Operations\)](#).

### 5.5.6 Low Air

If the NURO control displays either 65: "**Interrupted Airflow Switch OFF**" or 66: "**Interrupted Airflow Switch ON**", this indicates improper airflow through the appliance. First, verify proper standby blower operation – when the appliance is in "**Standby**", the blower should also be in standby.

Next, check for obstructions of the combustion air intake and/or exhaust (flue) piping. Next, check the hoses leading to the air switches are not kinked or obstructed. An error related to the air switch does not necessarily mean that the air switch is defective.

When 66: **“Interrupted Airflow Switch ON”** is displayed, check that the air switch is open when the blower is offline. Ensure there is no air flow through the appliance when the blower is offline. An excessive negative draft in the flue piping can cause air flow through the offline appliance which may be strong enough to maintain closure of the air switch.

When 65: **“Interrupted Airflow Switch OFF”** is displayed, check that the air switch is closed when the blower is running. If the air switch does not close within 5 minutes during purge, the appliance locks out. Check that the burner is clean ([5 Maintenance](#) and [5.2 Cleaning the Burner & Combustion Chamber](#)) and that there are no obstructions to airflow in the intake or exhaust ducts.

### 5.5.7 Low Air Intake Pressure

In the event the intake air pressure is too low, (air intake blockage), the NURO will display 10246: **“Low Air Intake Pressure”**. Check for restrictions in air intake flow.

### 5.5.8 Flame Failure

In the event of a flame failure, the NURO control may display one of the following error messages:

- 106: **“Flame Lost in Main Flame Establish Period”**
- 107: **“Flame Lost Early in Run”**
- 108: **“Flame Lost in Run”**
- 109: **“Ignition Failed”**
- 110: **“Ignition Failure Occurred”**

When 109: **“Ignition Failed”** or 110: **“Ignition Failure Occurred”** is displayed, the appliance did not light during the trial for ignition. Check that the ignition electrode, ignition wire, and gas valve are functioning properly. Check that the direct spark ignition is visible through the flame observation port during the trial for ignition.

When 106: **“Flame Lost in Main Flame Establish Period”**, 107: **“Flame Lost Early in Run”**, or 108: **“Flame Lost in Run”** is displayed, the appliance lost the flame signal during operation. Check that combustion is adjusted properly, the gas pressure is correct, and the ignition electrode, ignition wire, and gas valve are functioning properly.

### 5.5.9 Flame Error

In the event of a flame error (premature or late flame signal), the NURO control will display 105: **“Flame Detected Out of Sequence”**. This may be caused by a failed/leaky gas valve or a UV Scanner malfunction. If gas valve leakage is suspected, the unit must be isolated by turning off the main gas supply line. Lockout/tagout the appliance until qualified and knowledgeable service personnel are available to evaluate and repair or replace the failed parts. Check that the incoming gas pressures have not exceeded 14” W.C. (1/2 psig).

### 5.5.10 Flue Problem

When the normally-closed high exhaust back pressure switch opens, the NURO control will display 10013: **“High Back Pressure Limit”**. This may be caused by an obstruction in the flue piping, an obstruction in the combustion air intake, or a blocked condensate system. When the blockage is removed, the appliance will automatically restart. If no blockage is found, it may be necessary to replace the high exhaust back pressure switch.



## 6 Parts/Technical Support

Spare parts and replacement parts can be ordered from Harsco Industrial Patterson-Kelley by calling toll free (877) 728-5351. Reach us by fax at (570) 476-7247.

Refer to the parts list shown on the assembly drawings provided in this manual.

Technical information is also available by calling or visit the Harsco Industrial Patterson-Kelley website, [www.harscopk.com](http://www.harscopk.com).

When ordering replacement parts please have the model number and serial number of your appliance available.

Typical schematic drawings are shown on the following pages. Drawings specific to your particular appliance can also be supplied by your local Harsco Industrial Patterson-Kelley representative.

### **WARNING**

**Use of Non-Factory Authorized replacement parts are not recommended for this equipment. All control components are engineered for safety and are designed to work in unison with each of the other components. Use of non-factory authorized replacement parts jeopardizes the functionality of the safety features as well as the performance of the appliance.**

# 6.1 Appliance Parts Identification

## 6.1.1 Main Appliance Assembly

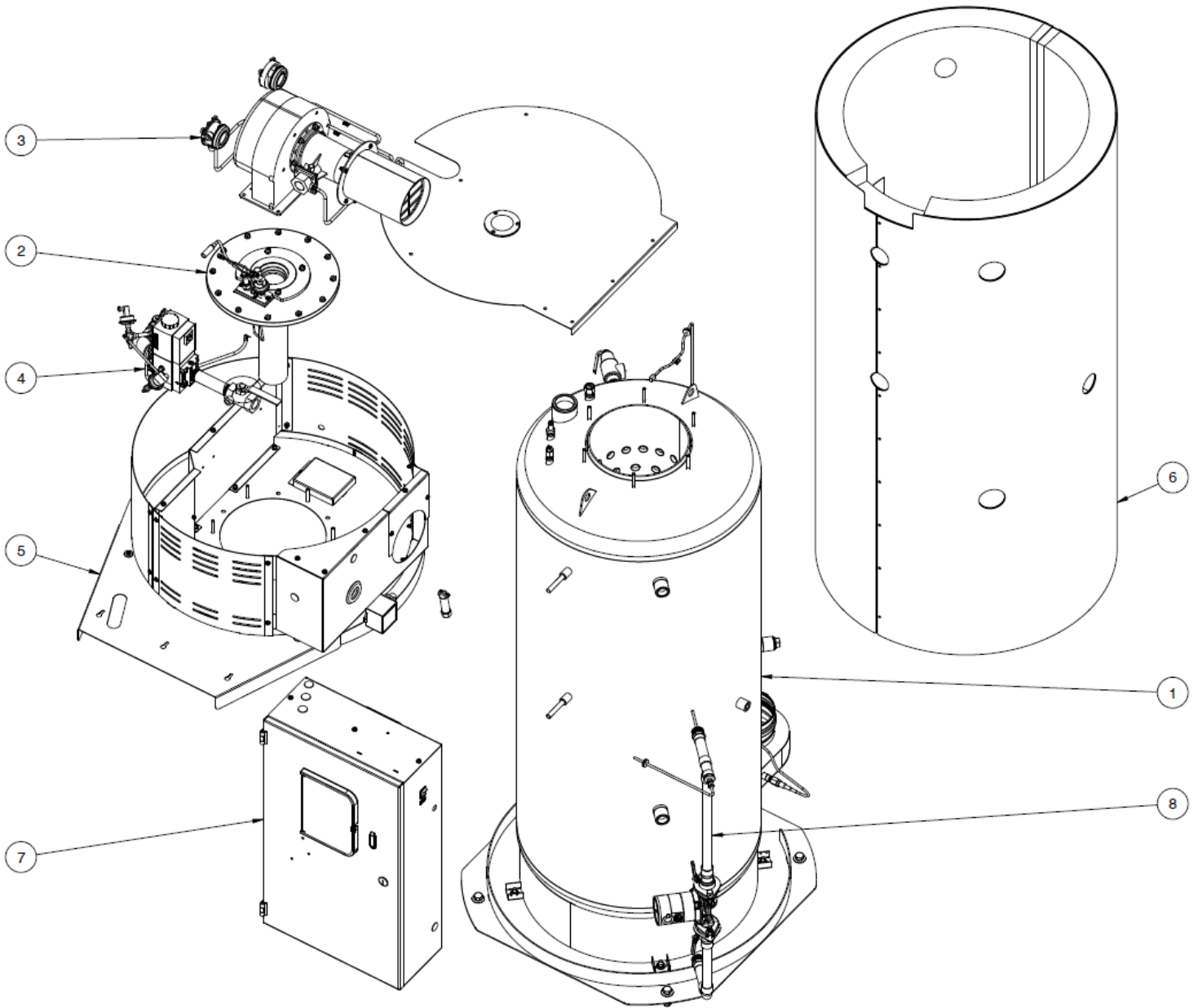

Mark	Description	Mark	Description
1	Heat Engine	5	Upper Cabinet Assembly
2	Burner Assembly	6	Cabinet Wrapper Assembly
3	Blower Assembly	7	Control Panel Assembly
4	Gas Train Assembly	8	Recirculation Line Assembly



## 6.1.2 NURO® Control Panel

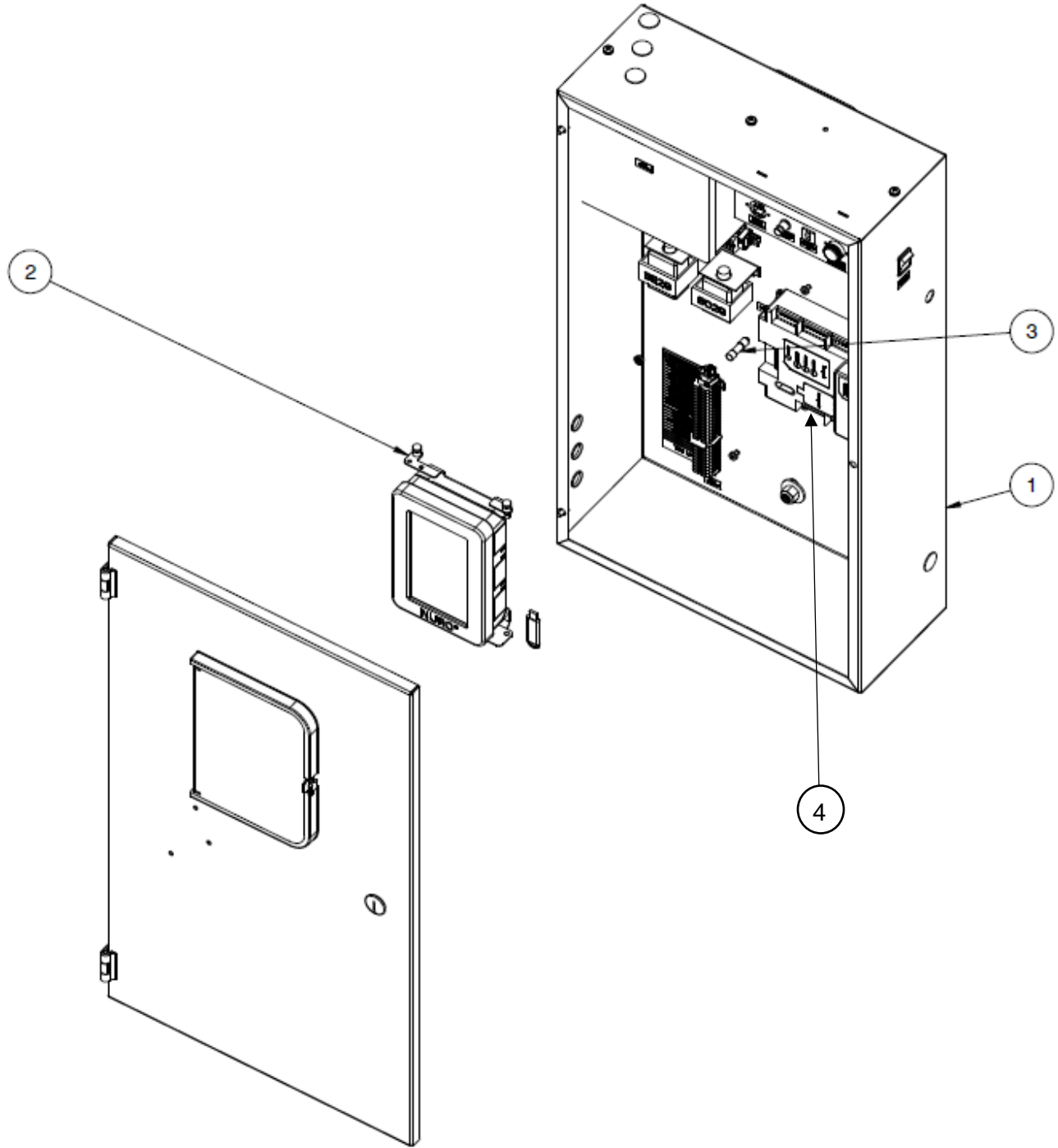

Mark	Description	Mark	Description
1	Control Panel Assembly	3	6A Fuse (HC800) 10A Fuse (HC1000)
2	Boiler Control Touch Screen Assembly	4	SOLA

### 6.1.3 Heat Exchanger Assembly

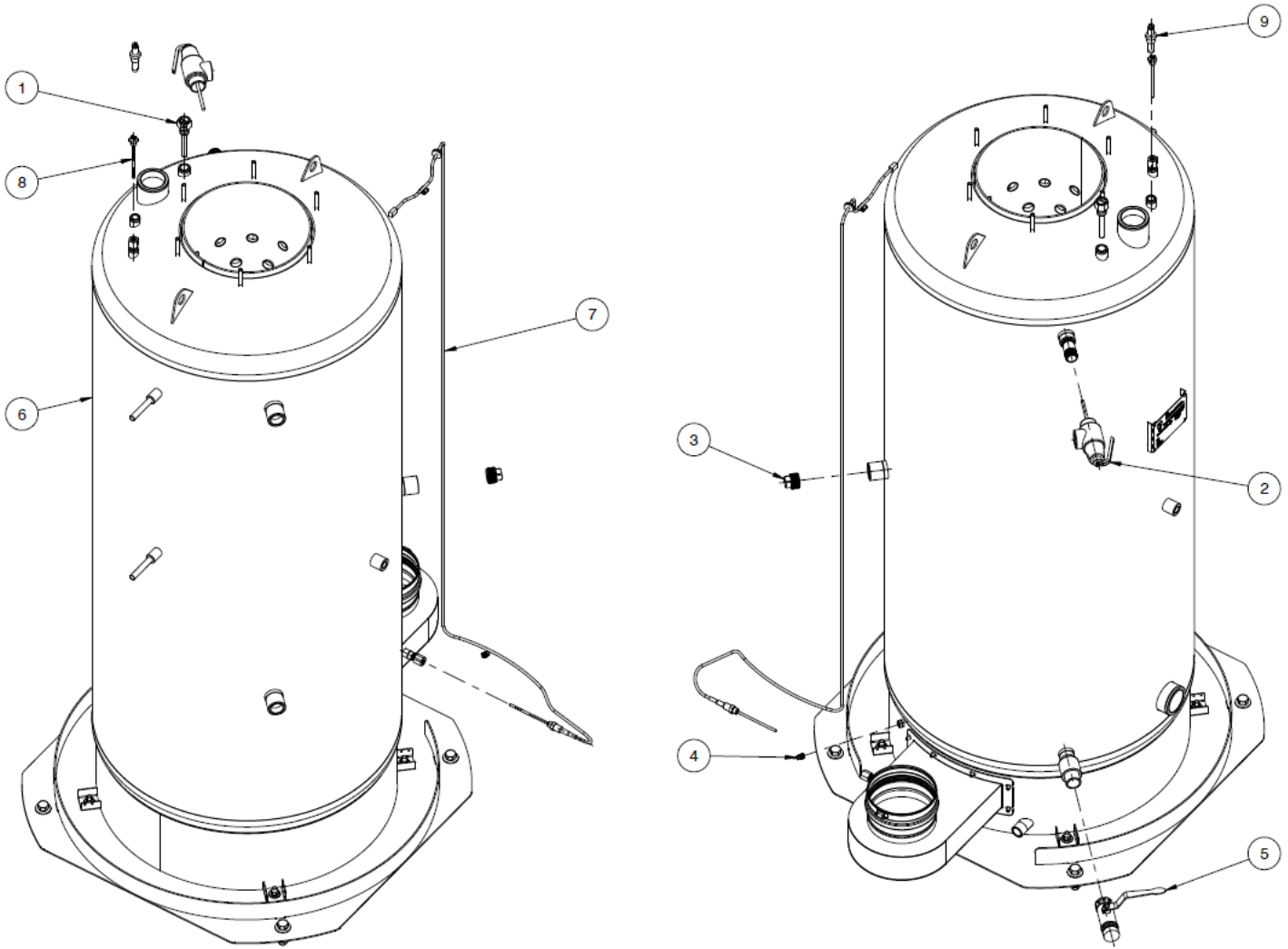

Mark	Description	Mark	Description
1	Thermowell	6	Heat Engine
2	3/4" Temp & Pressure Relief Valve	7	Stack Sensor Assembly
3	1" Pipe Plug	8	Outlet Sensor
4	1/8" Pipe Plug	9	LWCO Probe
5	1" Drain Valve		

### 6.1.4 Natural Gas Train (DUNGS Valve)

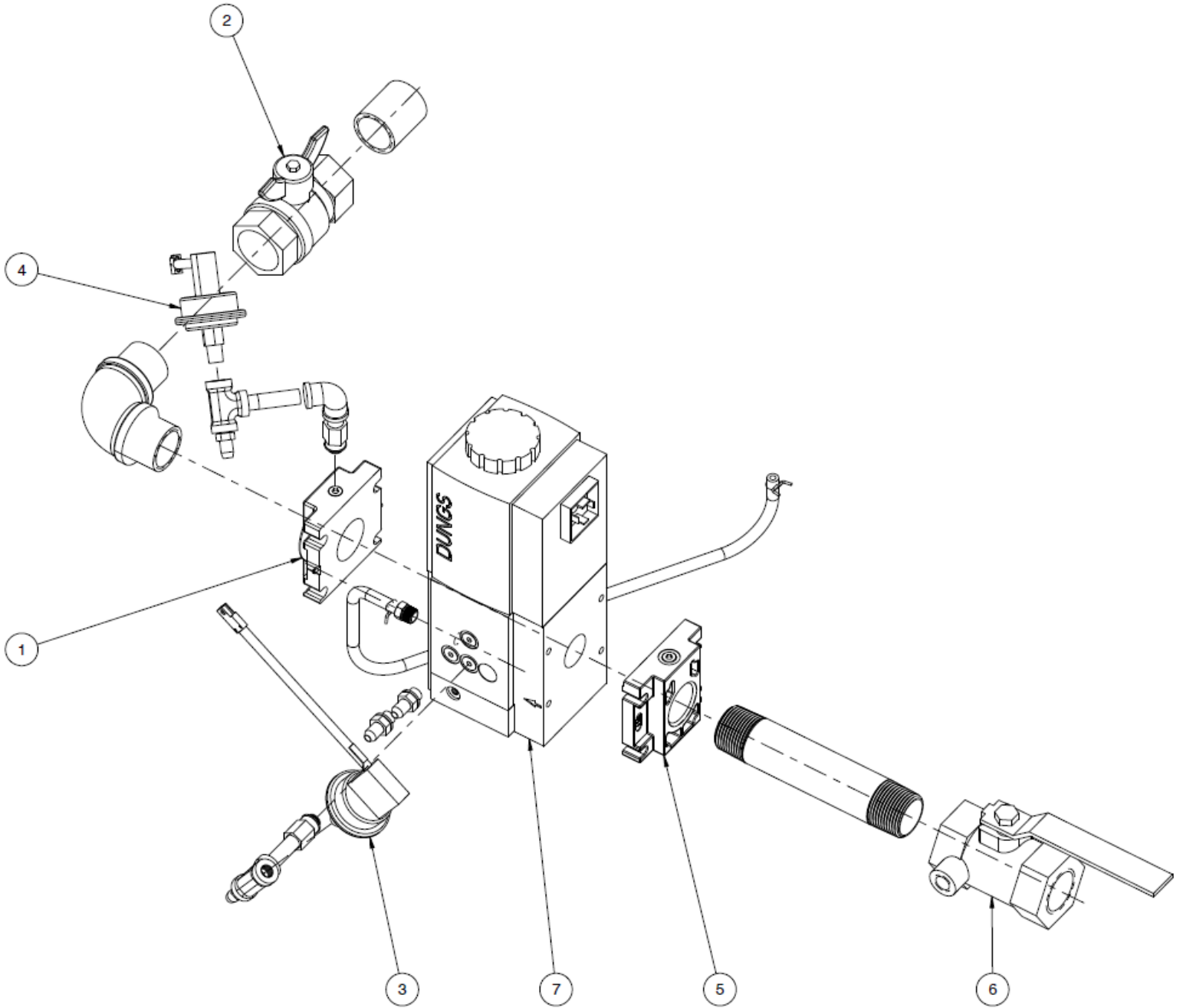

Mark	Description	Mark	Description
1	Flange	5	Flange
2	External (Upstream) Gas Cock (1" NPT-F)	6	Internal (Downstream) Gas Cock (1" NPT-F)
3	Low Gas Pressure Switch	7	DUNGS Gas Valve
4	High Gas Pressure Switch		

### 6.1.5 Natural Gas Train (Honeywell Valve)

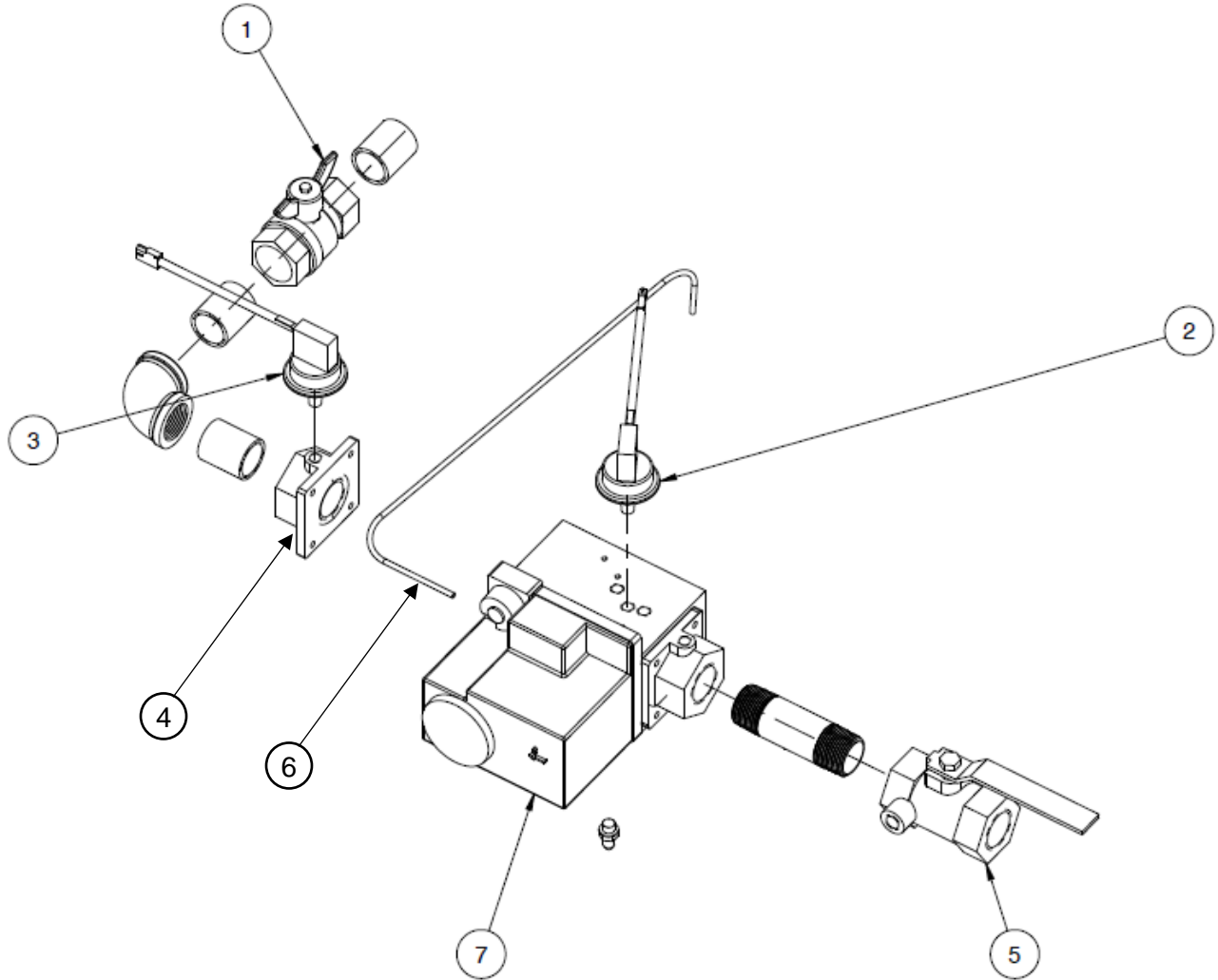

Mark	Description	Mark	Description
1	External (Upstream) Gas Cock (1" NPT-F)	5	Internal (Downstream) Gas Cock (1" NPT-F)
2	Low Gas Pressure Switch	6	Sensing Tube
3	High Gas Pressure Switch	7	Honeywell Gas Valve
4	Flange		

### 6.1.6 Blower Assembly

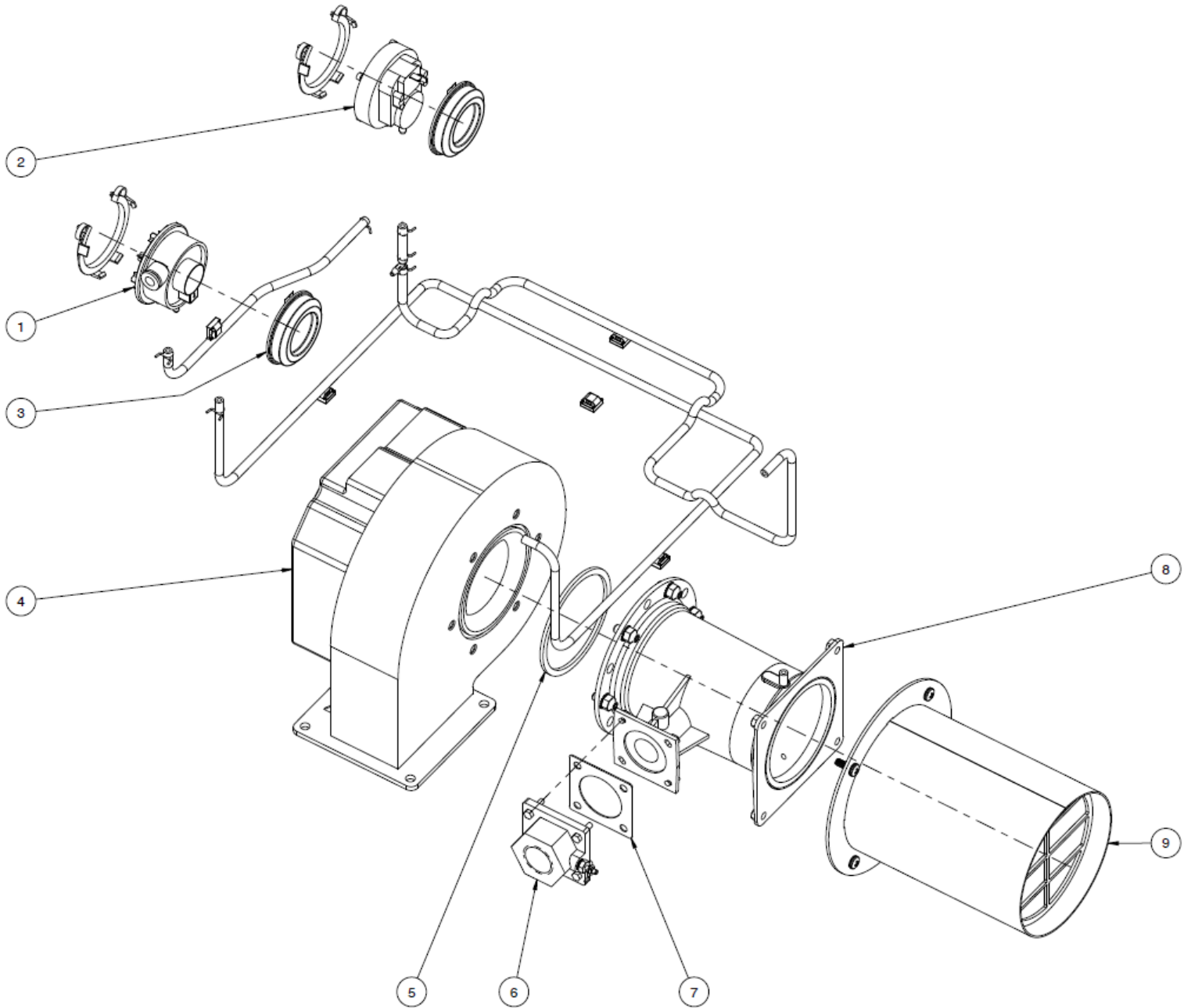

Mark	Description	Mark	Description
1	Air Switch	6	Flange
2	Low Air Intake Cut Off	7	Gasket
3	Air Switch Cover	8	Venturi
4	Blower	9	Air Intake
5	O-Ring		

### 6.1.7 Burner Assembly

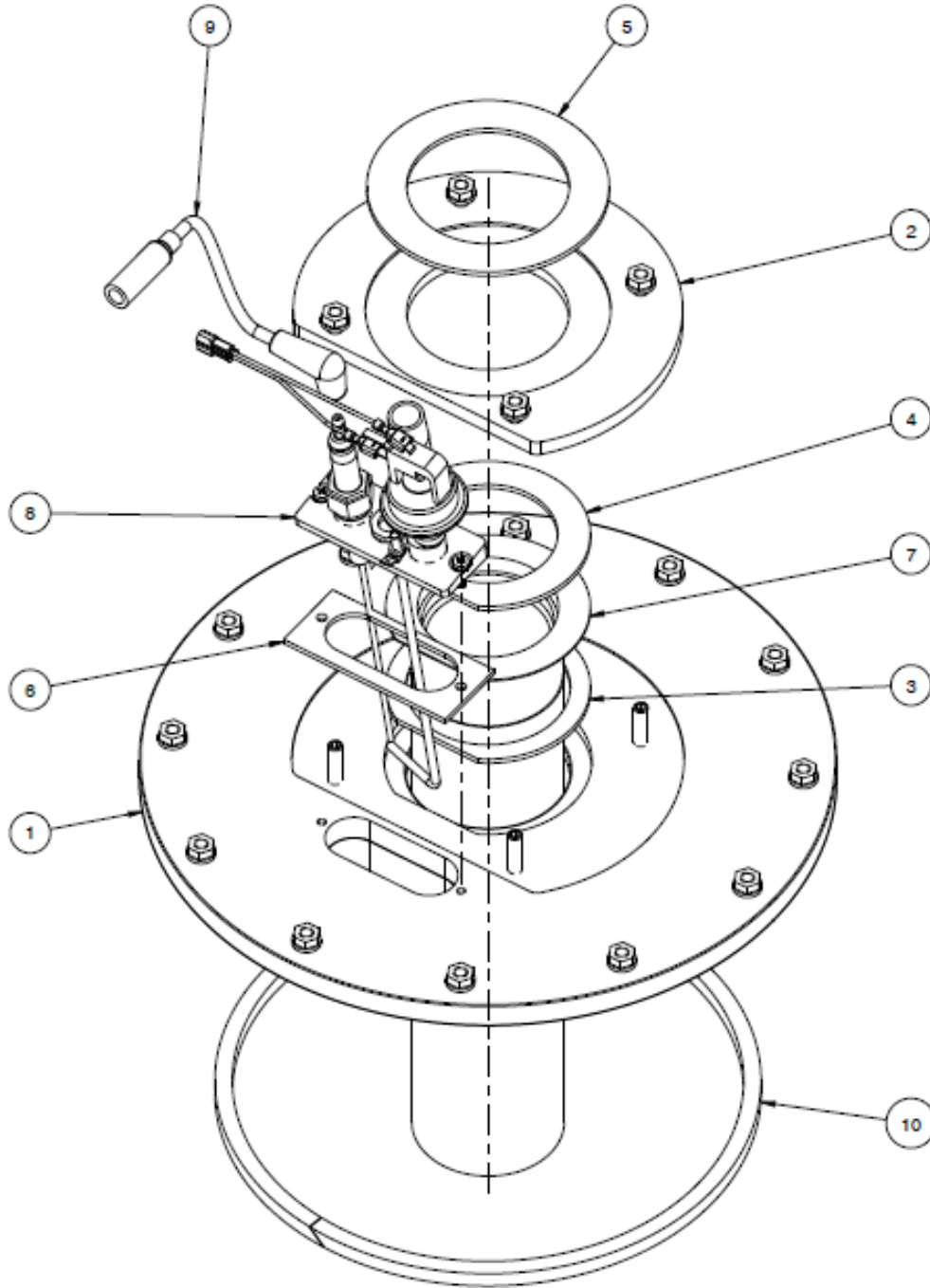

Mark	Description	Mark	Description
1	Burner Mounting Plate	6	Ignition Assembly Gasket
2	Burner Plate	7	Burner
3	Mounting Plate Gasket	8	Electrode Assembly
4	Burner Gasket	9	Ignition Cable
5	Burner Plate Gasket	10	Gasket

## 7 P-K HiDRA™ SPECIFIC LIMITED WARRANTY (HLW Hot Water Heater HC800-1000)

*Last Updated 3/12/2018*

When used for heating or storing potable water for domestic water heating purposes, this limited warranty covers defects in materials or workmanship of the tank and/ or heating surfaces that result in any of the following:

- Production of Rusty or Discolored Water
- Leaking
- Chloride Stress Corrosion Cracking
- Leaking due to Fireside Condensate Corrosion

Subject to the terms and conditions herein and the Terms and Conditions of Sale (as defined herein), Harsco Industrial Patterson-Kelley ("Seller") warrants to the purchaser of the product ("Buyer") that the heat exchanger and burner are free of defects in material and workmanship, when operated in accordance with the conditions stated herein, for a period of 15 years from the start of this warranty, if, in the judgment of Harsco Industrial Patterson Kelley, a warranty-covered defect of the tank or heating surfaces, Harsco Industrial Patterson-Kelley will replace the water heater with the then current equivalent model. The first 8 years will be at no cost to the owner for the water heater. From the beginning of the 9th year to the end of the 15th year will be the start of the limited warranty, Harsco Industrial Patterson Kelley will offer to sell the owner a new water heater of the then current equivalent model. The cost to the owner for the replacement water heater will be equal to the number of months in service from the date of start of this limited warranty, divided by the total number of months of this limited warranty, times the then current list price. At no point will the cost to the owner for the replacement water heater exceed 75% of the current list price. No labor or freight will be authorized or paid by Harsco Industrial Patterson Kelley. The warranty is only valid through a start-up report as furnished to Seller, commencing on the start-up date shown to Seller (the "Warranty Period"), if startup is completed within six (6) months of shipment and the start-up report is furnished to Seller within thirty (30) days of startup. The Exclusions and limitations of liability set forth in the Terms and Conditions of Sale (as defined herein) apply to this Specific Limited Warranty. Capitalized terms used but not defined herein have the meanings ascribed to them under Seller's terms and conditions of sale for the product, which can be found at <http://harscopk.com/warranty.php> (the "Terms and Conditions of Sale"). This Specific Limited Warranty is transferrable to the owner that utilizes the product(s) purchased hereunder for its intended use at the original installation site (the "Original Owner"). This Specific Limited Warranty is non-transferable to anyone who subsequently receives or purchases products from the Original Owner. If the Original Owner did not purchase the product directly from Seller, the Original Owner should contact the reseller from whom it purchased the product for a copy of the Terms and Conditions of Sale attached to the Order Acknowledgement received by the original purchaser of the product from Seller.

## **I. REMEDY**

Seller's obligations under this Specific Limited Warranty is limited to repairing or, if in Seller's judgment it seems more appropriate, to furnishing without charge (installation not included), FCA Seller's factory (Incoterms 2010), a similar part to replace any part which after examination shall, to Seller's own satisfaction be determined to have been defective at the time it was shipped. In the event that a replacement is provided by Seller, the defective item will become the property of Seller. Transportation to Seller's facility or other designated facility for repairs of any products or party alleged defective shall, in all events, be at Buyer's sole risk and cost. This warranty applies only if the original installer and Seller (Attention: Harsco Industrial, Patterson-Kelley, 155 Burson Street, East Stroudsburg, PA 18301) receive, within the Warranty Period, an immediate written notice, providing a detailed description of all claimed defects, upon discovery of such defects together with proof of purchase (invoice or Order Acknowledgment) and a copy of the start-up report for the affected product. Seller may seek reimbursement of any costs incurred by Seller where the product is found to be in good working order, or when it has been determined that this Specific Limited Warranty does not apply as per the exclusions set forth below. The remedies available to Buyer set forth herein are exclusive remedies, and all other remedies, statutory or otherwise, including but not limited to the right of redhibition, are waived by Buyer. Buyer acknowledges that the exclusion of remedies is neither unreasonable nor unconscionable. Buyer shall indemnify and hold Seller harmless against, any claim due to any injury or death to any person or damage to any property resulting in whole or in part from any modification or alteration Buyer makes to any product sold hereunder. In no event shall Seller liability on any claim arising out of or connected with the sales contract or the manufacture, sale, delivery, or use of the goods exceed the purchase price of the goods.

## **II. EXCLUSIONS**

To the full extent permitted by law, Seller shall have no liability for and the Warranties do not cover:

- (A) any product which has been altered or repaired by other than Seller's personnel;
- (B) deterioration or failure of any product due to
  - (i) abrasion, corrosion, erosion or fouling,
  - (ii) misuse,
  - (iii) modification not authorized by Seller in writing or

- (iv) improper installation, lack of or improper maintenance or operation;
- (C) equipment not furnished by Seller by the owner, either mounted or unmounted, or when contracted for by a party or parties other than Seller to be installed or handled;
- (D) the suitability of any product for any particular application;
- (E) the design or operation of owner's plant or equipment or of any facility or system of which any product may be made a part;
- (F) any damage to the product due to abrasion, erosion, corrosion, deterioration, abnormal temperatures or the influence of foreign matter or energy;
- (G) the performance of any product under conditions varying materially from those under which such product is usually tested under industry standards at the time of shipment;
- (H) leakage or other malfunction caused by:
  - (i) defective installations in general and specifically, any installation which is made
    - (a) in violation of applicable state or local plumbing, housing or building codes or
    - (b) contrary to the written instructions furnished with the product,
  - (ii) adverse local conditions in general and, specifically, sediment or lime precipitation in the tubes, headers and/or shells or corrosive elements in the water, heating medium or atmosphere, or
  - (iii) misuse in general and, specifically, operation and maintenance contrary to the written instructions furnished with the unit, disconnection, alteration or addition of components or apparatus, not approved by Seller, operation with heating media, fuels or settings other than those set forth on the rating plate or accidental or exterior damage;
- (I) production of noise, odors, discoloration or rusty water;
- (J) damage to surrounding area or property caused by leakage or malfunction;
- (K) costs associated with the replacement and/or repair of the unit including: any freight, shipping or delivery charges, any removal, installation or reinstallation charges, any material and/or permits required for installation, reinstallation or repair, charges to return the boiler and/or components;
- (L) INCIDENTAL, SPECIAL OR CONSEQUENTIAL DAMAGES, SUCH AS LOSS OF THE USE OF PRODUCTS, FACILITIES OR PRODUCTION, INCONVENIENCE, LOSS OF TIME OR LABOR EXPENSE INVOLVED IN REPAIRING OR REPLACING THE ALLEGED DEFECTIVE PRODUCT;
- (M) any claim due to any injury or death to any person or damage to any property resulting in whole or in part from any modification or alteration Buyer makes to any product sold hereunder; and
- (N) Design defects where Seller has complied with Buyer's design specifications.

### **III. PROOF OF PURCHASE**

Proof of purchase (invoice or Order Acknowledgement) and a copy of the start-up report for the affected product must be provided to Seller when requesting service under this Specific Limited Warranty.

### **IV. ORDER OF PRECEDENCE**

The Standard Limited Warranty set forth in the Terms and Conditions of Sale, (b) this Specific Limited Warranty and (c) any applicable Extended Limited Warranty exclusively govern and control Seller's and Buyer's respective rights and obligations regarding the warranty of the product. In case of any inconsistency, conflict, or ambiguity between the Standard Limited Warranty, this Specific Limited Warranty and any applicable Extended Limited Warranty (collectively, the "Warranty Documents"), the documents shall govern in the following order: (w) any applicable Extended Limited Warranty; (x) this Specific Limited Warranty; (y) the Standard Limited Warranty and (z) other provisions in the Terms and Conditions of Sale. Information identified in one Warranty Document and not identified in another shall not be considered a conflict or inconsistency. No sales representative, agent, or employee of Seller or any reseller in the chain of sale of the product is authorized to make any modification, extension, or addition to this Specific Limited Warranty, unless agreed to in writing by Seller.



# 8 Appliance Fire-Test Report



## P-K APPLIANCE START-UP REPORT

Date: \_\_\_\_\_

Serial # \_\_\_\_\_ Model # \_\_\_\_\_

Installation: Name: \_\_\_\_\_ City: \_\_\_\_\_

State: \_\_\_\_\_ Zip: \_\_\_\_\_ Contact \_\_\_\_\_ Phone: \_\_\_\_\_

Installer Name: \_\_\_\_\_ Type of Installation: \_\_\_\_\_ (Hotel, School, etc.)

Fuel: Natural Gas \_\_\_\_\_ Propane \_\_\_\_\_

Field Fire-Test	High	Low	DATE:
Inlet Gas	_____ "w.c.	_____ "w.c.	
Oxygen (O2)	_____ %	_____ %	
Carbon Dioxide (CO2)	_____ %	_____ %	
Carbon Monoxide (CO)	_____ ppm	_____ ppm	
Nox	_____ ppm	_____ ppm	
Gross Stack Temp.	_____ ° F	_____ ° F	
Combustion Air Temp.	_____ ° F	_____ ° F	
Stack Press.(exhaust)	_____ "w.c.	_____ "w.c.	
Main Flame Signal	_____ Volts or uA	_____ Volts or uA	
Efficiency	_____ %	_____ %	
Comb. Air Pres. (intake)	_____ "w.c.	_____ "w.c.	

**Lockup/Static Gas pressure**

Gas pressure drop @ ignition \_\_\_\_\_

2. Water Outlet temperature: \_\_\_\_\_ ° F

3. Operating Temperature Setpoint: \_\_\_\_\_ ° F (from internal OR external control)

4. Approximate stack lengths: \_\_\_\_\_ Ft. Horizontal \_\_\_\_\_ Ft. Vertical \_\_\_\_\_ Flue Pipe Diameter

5. Incoming Electrical Power \_\_\_\_\_ Volts a.c.  Less than 1 volt between neutral and ground

6. Sytem Water pH level \_\_\_\_\_

7. Hardness: \_\_\_\_\_ GR or PPM

8. Comments:

Performed by: \_\_\_\_\_ (Print Name) Start Up Certification # \_\_\_\_\_

A copy must be returned within 30 days of startup to Harsco Industrial Patterson-Kelley  
 Harsco Industrial Patterson-Kelley • 155 Burson Street • E. Stroudsburg, PA 18301  
 P) 570-476-7261 F) 570-476-7247 www.pkboilers.com

# Appendix A – Maintenance Log

Date	Hi Fire / Low Fire	O <sub>2</sub>	CO	CO <sub>2</sub>	Stack Temp	pH	Action	By

PRELIMINARY DOCUMENT - SUBJECT TO CHANGE

## Appendix B – Appliance Altitude Derate Schedule

For installations over 2,000 ft. elevations, a derate schedule is applied. The appliance input rating must be reduced by 4% per 1,000 ft. which is illustrated in the graph below.

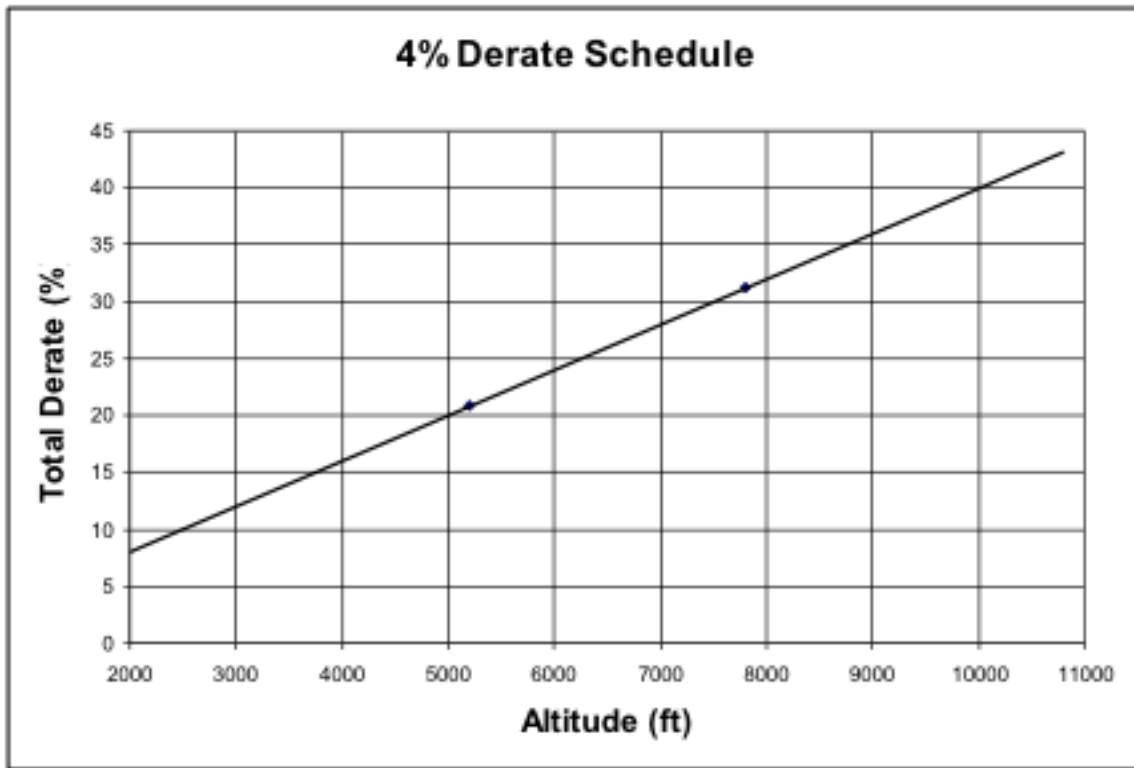

Although the appliance's capacity is reduced due to the lower air density, the combustion tuning should follow the standard combustion guidelines of [4.4](#). Tune the combustion for the same O<sub>2</sub> and CO<sub>2</sub> levels as discussed in [4.4.2](#).

## Appendix C – Water Quality Standards

The water hardness should be between 1 grain and 6 grains per gallon (17 ppm and 103 ppm). If the water hardness exceeds these levels, water softening may be required to prevent premature exchanger failure.

**NOTICE!** Do not use deionized water with a P-K HiDRA water heater.

Air elimination from the domestic water is extremely important in any hot water system. Ensure that automatic air vents are installed in areas of piping that are prone to trap pockets of air.

Water hammer occurs when there are dramatic fluctuations of the water pressure inside the domestic hot water system, and can be heard throughout the domestic water piping. This can occur when the hot water fixtures open and close too quickly, forcing the water pressure to surge momentarily. This can also occur when the pressure reducing valve for the makeup water opens and closes too quickly, which also forces the pressure to surge momentarily. If the domestic water system features these types of fixtures or pressure reducing valves and water hammer is occurring, water hammer arrestors or an expansion tank may be required to dampen the pressure spikes.

## Appendix D Best Practices For New & Retrofit Systems

### BEST PRACTICES FOR ALL WATER HEATER INSTALLATIONS

1. Patterson-Kelley recommends and most installation codes require isolation valves on both water heater's inlet (return) and outlet (supply) pipe runs. These are used to hydraulically isolate water heater from system, which should be standard practice when flushing.
2. Patterson-Kelley recommends installing purge valves on system side of water heater's isolation valves. These valves should be used to purge the domestic hot water system of debris and sediment prior to the initial startup of water heater equipment. Since purge valves are located on the system side of the water heater's isolation valves, debris and sediment will not be routed in direct proximity to water heater exchanger.
3. Patterson-Kelley recommends installing a standard mesh strainer (maximum 20 mesh) on each water heater's inlet (return) piping. This is intended to prevent large particles, foreign debris, etc. from entering and obstructing flow or heat transfer through water heater's heat exchanger. Each strainer should feature a manual blow-down valve in order to purge debris from strainer.  
**NOTE:** This strainer is not intended to remove fine particulate matter from domestic water system.
4. Oxygen (O<sub>2</sub>) elimination is critical to the longevity of any domestic water system. Patterson-Kelley recommends installing Automatic Air Vents in the "high points" of the piping in order to purge the system of dissolved Oxygen and air. Automatic Air Vents are preferred over manual air vents in order to continually purge the domestic water system.
5. Water hammer can lead to premature failure of heat exchanger. Patterson-Kelley suggests including water hammer arrestors or an expansion tank to dampen spikes in water pressure.
6. The maximum flow rate requirements vary between Patterson-Kelley water heater models. Please refer to [Appendix E – Installation and Quick Reference](#) for a complete listing of maximum flow rates per water heater model. Exceeding maximum flow rate of a water heater can cause erosion of heat exchanger or piping materials and can damage low water cutoff.
7. Well in advance of equipment startup, turn off all circulation pumps and close isolation valves on each water heater's inlet (return) and outlet (supply) pipe runs. Connect a hose to purge valves and run this hose to a nearby floor drain. Open each purge valve to flush out debris that is present in water. This process may take several attempts until discharge water is sufficiently clean. After successfully purging system, make sure to open the water heater's isolation valves and turn on circulation pumps.
8. Upon startup, Patterson-Kelley recommends collecting two water samples: one from domestic hot water system and another from cold water fill. **NOTE:** The water hardness should be between 1 grain and 6 grains per gallon (17 ppm and 103 ppm). If the water hardness exceeds these levels, water softening may be required to prevent premature heat exchanger failure.
9. Patterson-Kelley recommends a minimum annual water sample rate to determine any changes in pH, Alkalinity, conductivity, etc. that may adversely affect system performance.
10. Good Engineering practice mandates use of thermostatically or electrically controlled mixing valves set at 120°F or less to keep delivered water temperature below scalding levels. Consult local building codes and requirements for specific mandates in this regard.

# Appendix E – Installation and Quick Reference

## Fuel/Gas Supply

- Refer to [3.7 Piping](#) for information on proper sizing of the gas supply piping. Undersized gas piping with too much pressure drop will negatively impact the appliance’s performance.
- Install a lock-up type gas regulator to supply an appropriate gas pressure as described below:

<b>Natural Gas</b>
Minimum Inlet Pressure = 3.5” W.C.
Maximum Inlet Pressure = 14.0” W.C.

**NOTE**

Harsco Industrial Patterson-Kelley recommends installing an individual lock-up type gas regulator in the gas supply piping to each appliance. For installations where one master lock-up type gas pressure regulator will service multiple appliances, Patterson-Kelley recommends contacting the local regulator representative for application assistance specifying the appropriate lock-up type regulator and gas pipe sizing.

## Electrical/Power Supply

- Carefully inspect the appliance’s nameplate labels which describe the power supply requirements.
- Provide an appropriate power feed to the appliance with overcurrent protection:

Water Heater Model	Power Supply Requirements
HC800	110-120VAC, <b>single phase</b> , 60Hz sized for a minimum of 6 Amps.
HC1000	110-120VAC, <b>single phase</b> , 60Hz sized for a minimum of 10 Amps.

- Prior to startup, carefully check all electrical connections for tightness as connections can come loose during shipping.

## Exhaust Venting

- The P-K HiDRA appliances are dual-certified as Category II & Category IV appliances, capable of operating with slightly negative to slightly positive exhaust pressure. It is critical to ensure the flue venting material is suitable for use with the appliance.
- For Category II installations, ensure the flue venting system is designed to maintain a slightly negative exhaust pressure between -0.01” W.C. and -0.05” W.C.
- For Category IV (sealed combustion) installations, ensure the flue venting system is designed to maintain a slightly positive exhaust pressure which does not exceed +1.0” W.C.
- For Category IV (exhaust only) installations, ensure the flue venting system does not exceed +1.0” W.C.

# Appliance Connections

All water connections should be in compliance with national, state and local code requirements.

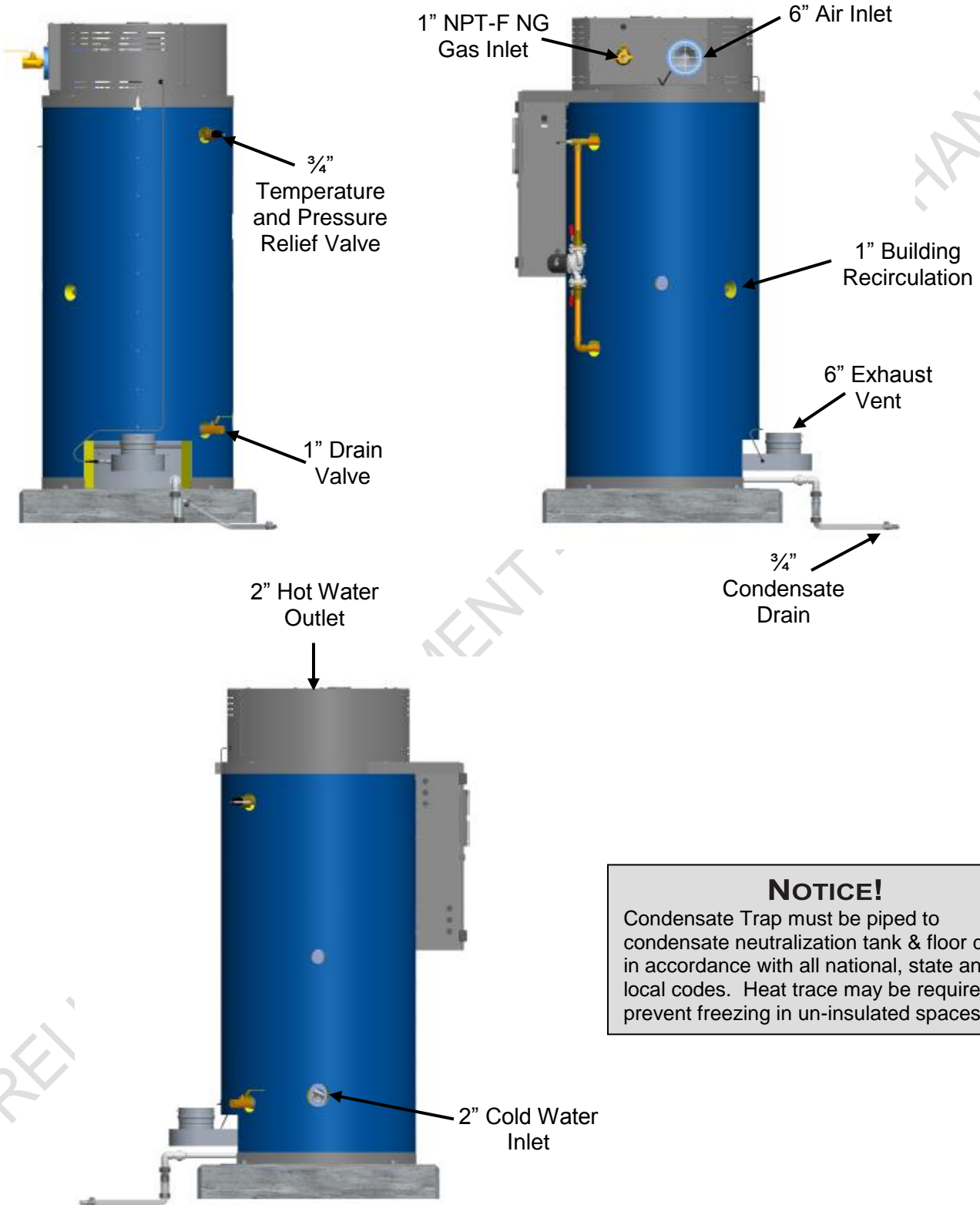

**NOTICE!**  
Condensate Trap must be piped to condensate neutralization tank & floor drain in accordance with all national, state and local codes. Heat trace may be required to prevent freezing in un-insulated spaces.